

TRACFINDER RAIL

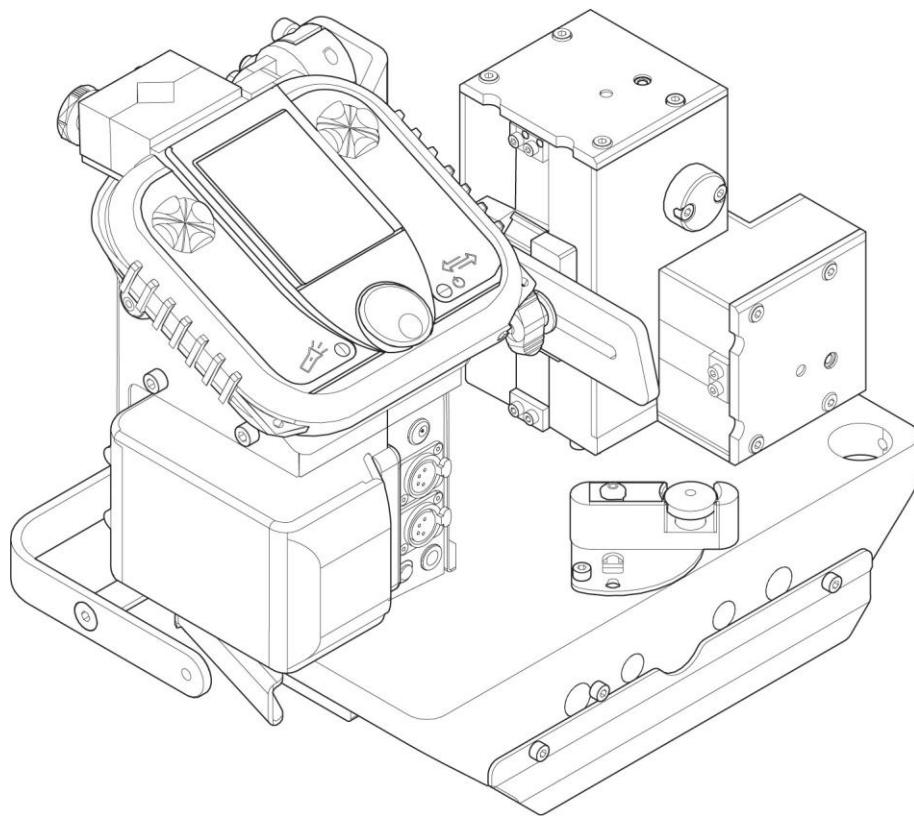

User's Guide

1	SAFETY	4
1.1	Meaning of the symbols	4
1.2	Safety Precaution.....	4
2	INTRODUCTION	7
3	TECHNICIAN DATA	8
3.1	Dimension Drawings	8
4	INSTALLATION	9
4.1	Description of rail foot.....	9
4.2	Flashlight connection.....	10
4.3	Connecting the trolley to the track	11
4.4	Installing the Battery Pack	11
4.5	Charging the remote control	12
5	OPERATION	13
5.1	Connecting the exhaust	13
5.2	Connecting accessories.....	13
5.3	To connect the arc detector.....	14
5.4	Turning the cart on and off	14
6	CONTROL PANEL	15
6.1	Description of standard tower	15
6.2	Description of the Programmable Tower and Remote Control.....	16
6.3	Description of the standard tower interface	17
6.3.1	Main Screen Display.....	17
6.3.2	Access to product information	17
6.3.3	Accessing the Advanced Settings Menu	18
6.3.4	Time schedules.....	19
6.3.5	Programmable mode enabled “ON” [P]	20
6.4	Remote panel interface description	22
6.4.1	Remote control interface for extended HMI.....	22
6.4.2	Transportation orders	23
6.4.3	Archiving of orders.....	24
6.4.4	Cycle Configuration	25
6.4.5	Cycle Shapes.....	25
6.4.6	Welding.....	26
6.4.7	Plasma cutting	27
6.4.8	Preferences for	28
6.4.9	Time schedules.....	29
6.4.10	Settings of the connected axes	32
6.4.11	Limits.....	34
6.4.12	Zero point setting	34
6.4.13	Collaborative learning	35
6.4.14	Machine Configurations	37
6.4.15	Axis guidance (manual mode).....	38
6.4.16	Role of the user	40
6.5	Switching the remote control on, pairing and off	41
6.5.1	Switching on and off	41
6.5.2	Pairing the remote control.....	41
6.5.3	Button Configurations	42

TABLE OF CONTENTS

6.6	Advanced cradle configuration	42
6.7	Performing software updates	48
6.7.1	Updating tractor	48
6.7.2	Remote control update	49
6.7.3	Update of accessories (communication box, axles, etc.)	51
7	MAINTENANCE	52
7.1	Periodical maintenance checks	52
7.2	Instructions for maintenance and replacement of rails	52
7.3	Changing the rollers	54
8	TROUBLESHOOTING	55
9	ORDERING SPARE PARTS	56
	REFERENCES	57
	Accessory Items	58

1 SAFETY

1.1 Meaning of the symbols

As used in this manual: **Caution Work with care!**



DANGER!

Indicates an immediate hazard which, if not avoided, will result in immediate serious injury or death.



WARNING!

Indicates a potential hazard that could result in injury or death.



CAUTION!

Indicates a hazard that could result in minor or moderate injury.



WARNING!

Before use, read and understand the operating instructions and follow all labeling, employer's safety regulations and safety data sheets (SDS).



1.2 Safety Precaution

Users of ESAB equipment are ultimately responsible for ensuring that all persons working on or near the equipment follow all relevant safety precautions. The safety precautions must comply with the requirements applicable to this type of equipment. The following recommendations must be observed in addition to the standard regulations applicable to the workplace.

All work must be carried out by trained personnel who are familiar with the operation of the equipment. Improper operation of the equipment can lead to hazardous situations that can cause injury to the operator and damage to the equipment.

1. Everyone who operates the equipment must be familiar with the following:
 - Its operation
 - Location of emergency stop buttons
 - Its function
 - Relevant safety precautions
 - Welding and cutting or other applicable operation of the equipment
2. The operator must ensure that:
 - no unauthorized person is in the working area of the system when it is put into operation
 - nobody is unprotected when the arc flashes over or work on the equipment is started
3. The workplace must
 - fit for purpose
 - be free of drafts
4. Personal Protective Means
 - Always wear the recommended personal protective equipment such as safety glasses, fire-resistant clothing and protective gloves.
 - Do not wear loose items such as scarves, bracelets, rings, etc. that can get caught or cause burns.

5. General remark

- Make sure that the return cable is securely connected.
- Work on high-voltage systems **may only be carried out by a qualified electrician**
- Suitable fire extinguishing equipment must be clearly marked and within reach
- Lubrication and maintenance work must **not** be carried out during operation

**WARNING!**

Arc welding and arc cutting can injure you and others. Take precautions when welding and cutting.

**ELECTRIC SHOCK – Can be fatal**

- Install and ground the equipment according to the instruction manual.
- Do not touch live electrical parts or electrodes with bare skin, wet gloves or wet clothing.
- Isolate yourself from work and the ground.
- Ensure a safe working position

**ELECTRICAL AND MAGNETIC FIELDS – May be harmful to health**

- Welders with pacemakers should consult their doctor before welding. EMF can interfere with some pacemakers.
- Exposure to EMF may have other unknown health effects.
- Welders should use the following procedures to minimize exposure to EMF:
 - Place the electrode and working cable together on the same side of the body. Secure them with tape if possible. Do not place your body between the torch and the working cables. Never wrap the torch or the working cable around your body. Keep the welding source and cable as far away from the body as possible.
 - Connect the working cable to the workpiece as close as possible to the area to be welded.

**FUMES AND GASSES – Hazardous to health**

- Keep head away from vapors
- Use ventilation, arc extraction, or both to remove fumes and gasses from your breathing zone and the general area

**ARC RADIATION – May cause eye and skin damage**

- Protect your eyes and body. Use correct welding shield and filter glass and wear protective clothing
- Protect bystanders with appropriate screens or

**NOISE – Excessive noise can damage hearing**

Use ear protectors. Wear ear protection or other hearing protection.

**MOVING PARTS – Risk of injury**

- Keep all doors, panels and covers closed and securely in place. Only allow qualified personnel to remove covers for maintenance and troubleshooting. Replace the covers and close the doors after completing maintenance and before starting the engine.
- Switch off the engine before installing or connecting the unit.
- Keep hands, hair, loose clothing and tools away from moving parts.





FIRE HAZARD

- Sparks (splashes) can cause fires. Ensure that there are no combustible materials nearby
- Do not use in closed containers.



HOT SURFACE – Parts can burn

- Do not touch parts with bare hands.
- Wait until the equipment has cooled down before working on it.
- Use suitable tools and/or insulated welding gloves when handling hot parts to avoid burns.

MALFUNCTION – In the event of a malfunction, seek professional assistance.

PROTECT YOURSELF AND OTHERS!



NOTE!

Dispose of electronic devices at the recycling plant!

According to the European Directive 2012/19/EC on waste electrical and electronic equipment and its implementation in accordance with national law, electrical and/or electronic equipment that has reached the end of its service life must be taken to a recycling facility.

As the person responsible for the equipment, it is your responsibility to find out about approved collection points.

Contact your nearest ESAB dealer for more information.



2 INTRODUCTION

The machine is a stand-alone cart on a guide rail designed specifically for mechanized semi-automatic welding in all positions. The TRACFINDER RAIL is designed to move along a fixed RAIL. It carries a welding torch and ensures smooth linear movement.

The carriage is usually equipped with gears and rollers that fit exactly on the rail. This cradle is designed for use with tower and interface. The machine is equipped with a control unit, each intended for use by a single operator.

The most important features of TRACFINDER RAIL:

- Lightweight and durable.
- Automated movement.
- It is easy to use and set up.

3 TECHNICIAN DATA

TRACFINDER RAIL	
Dimensions (L × W × H)	345 × 220 × 225
Weight	7 Kg
Mains power supply	18 Vdc, 5 Ah
Operating autonomy for a 5 Ah, 18 V battery	From 8 to 20 hours*
Charging time for a 5Ah, 18V battery	45 min
Slide speed with full battery 5Ah, 18V	From 1 to 180 cm/min
Temperature Range	-5°C (23°F) and 60°C (140°F)
Noise emission (LPA)	< 70 dB (A)
Autonomy of the remote control	Eight hours
Protection class:	IP43

* Depending on configuration

3.1 Dimension Drawings

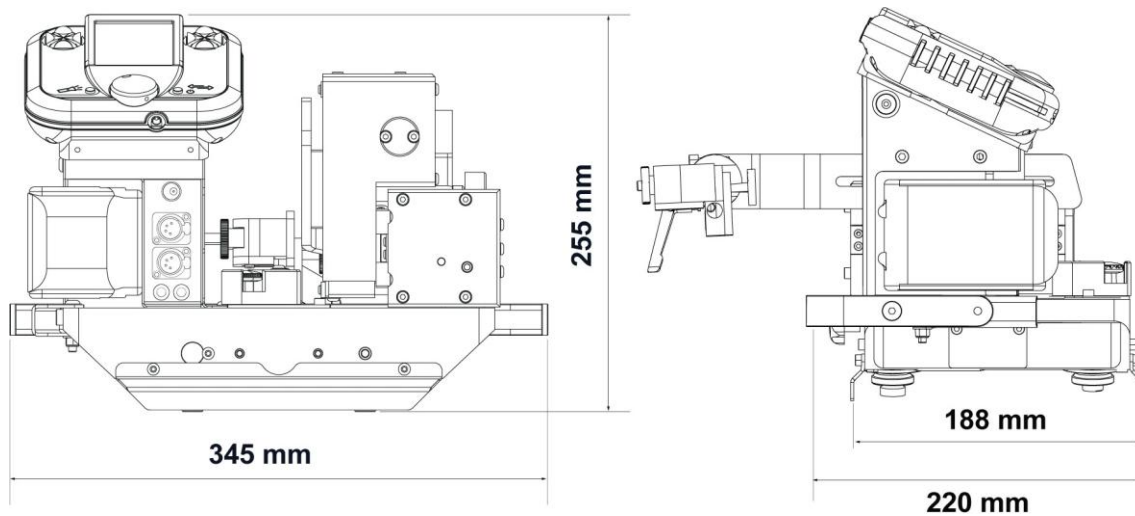

4 INSTALLATION



CAUTION!

This product is intended for industrial use. It is the responsibility of the user to take appropriate precautions.

4.1 Description of rail foot

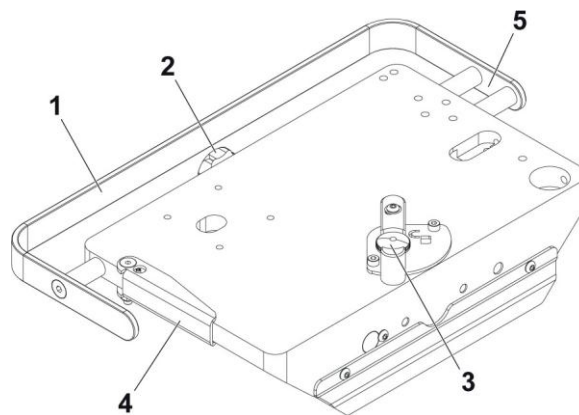

- **Handle (1):** Lifts the trolley ergonomically to move it.
- **Selection wheel (2):** for aligning the guide rollers when positioning the soft rail over a curved part. The middle position corresponds to propping on a level surface.
- **Locking handles (3):** for locking/unlocking the guide rollers on the guide rail to hold the carriage on the rail.
- **Motor clutch lever (4):** for manual rolling of the carriage on the rail.
- **Reinforced docking area (5):** for docking the trolley for additional safety in case of loss of magnetic or pneumatic adhesion of the rail.

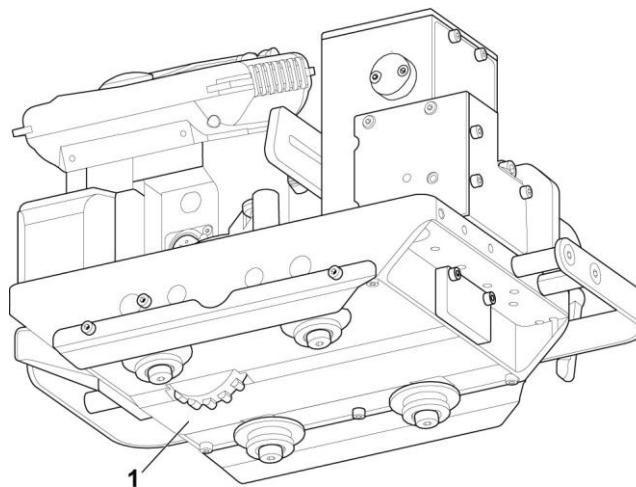

- **Housing (1):** controls, repairs and maintains the skidding equipment.

4.2 Flashlight connection

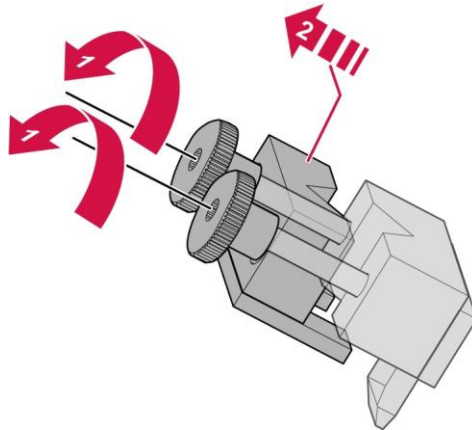

- 1) Loosen the threaded nuts around the burner neck.
- 2) Remove the single jaw.

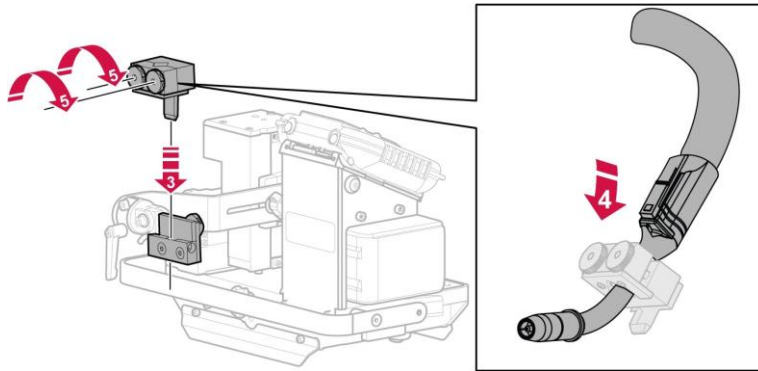

- 3) Insert the tool holder into the slide.
- 4) Insert the torch between the two jaws.
- 5) Retighten the screws on the jaws.



WARNING!

The jaw must point downwards to allow detection with the arc detector.

4.3 Connecting the trolley to the track

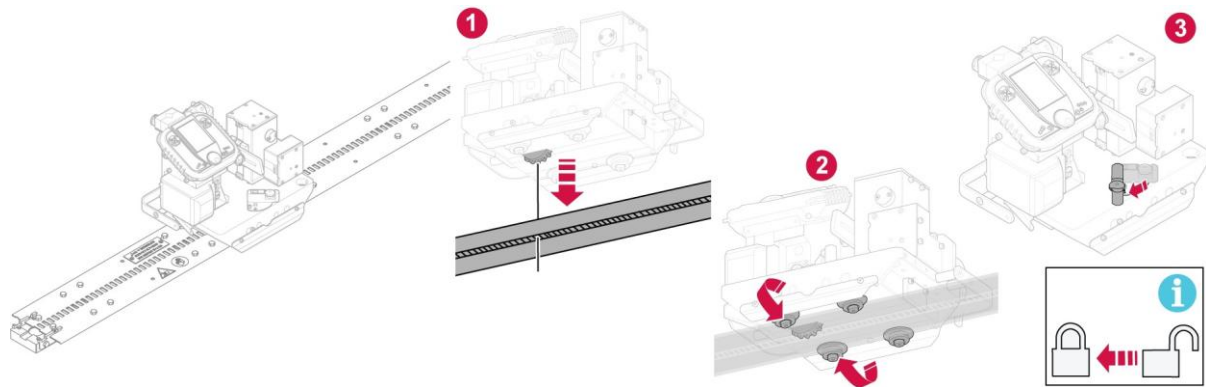

- 1) When placing the trolley on the rail, check that the gearbox is correctly mounted on the rail.
- 2) Support the guide rollers on the rain gutter.
- 3) Lock it by turning the handle.

4.4 Installing the Battery Pack

The cart is designed for operation with an 18V Li-Ion battery or with an optional external power supply.

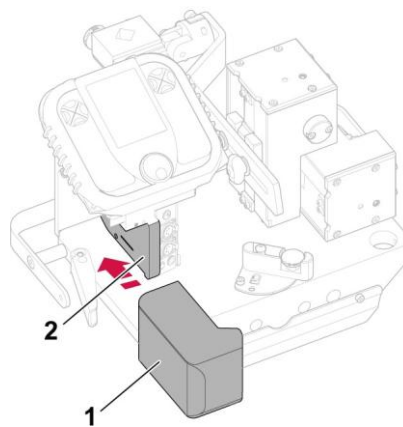

- 1) Disengage the battery (1) by pressing the release button before removing it from the holder (2).



WARNING!

It is important to clean the holder thoroughly with compressed air or a clean cloth before inserting a battery. Risk of malfunction.

- 2) Insert battery (1) into mount (2) up to end stop of retaining clamps.



WARNING!

In the event of a defective battery, it must be disposed of separately in accordance with national regulations and the European Directive so that it can be either recycled or dismantled in order to reduce any impact on the environment.

4.5 Charging the remote control

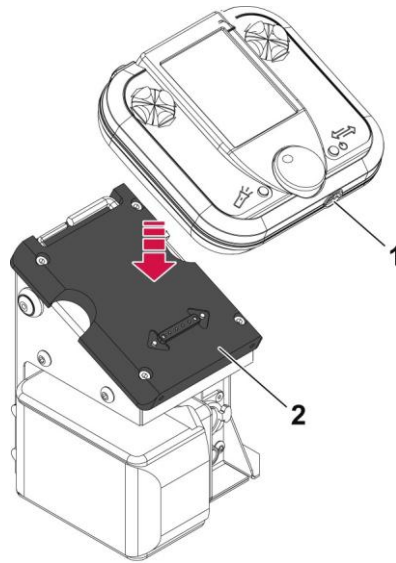

The remote control is powered by an internal battery. Charging can be done in two ways.

1) Charge the internal battery by:

- When not in use via a charger at a 230 V socket connected to a charging connection (1).
- During use, the remote control is placed in the charging station on the remote-controlled tower (2).

**WARNING!**

If the remote control switches off in the middle of the cycle due to low battery power, the cycle continues. The remote control can then be placed on the charging station to complete the cycle.

**NOTE!**

The remote control is held on the charging station by magnets to prevent it from falling.

5 OPERATION



CAUTION!

This product is intended for industrial use. It is the responsibility of the user to take appropriate precautions.

5.1 Connecting the exhaust

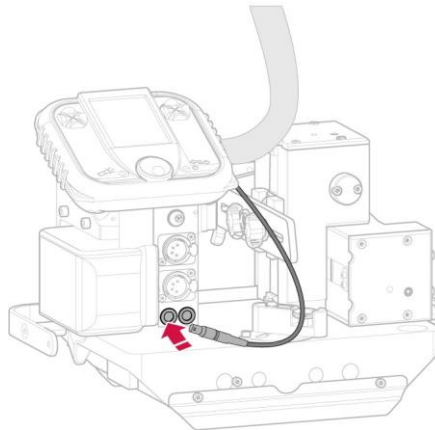

- 1) Connect the trigger cable to the control connector.
- 2) The welding arc is synchronized with the movement of the carriage. Activate by pressing the cycle start button on the cradle.

5.2 Connecting accessories

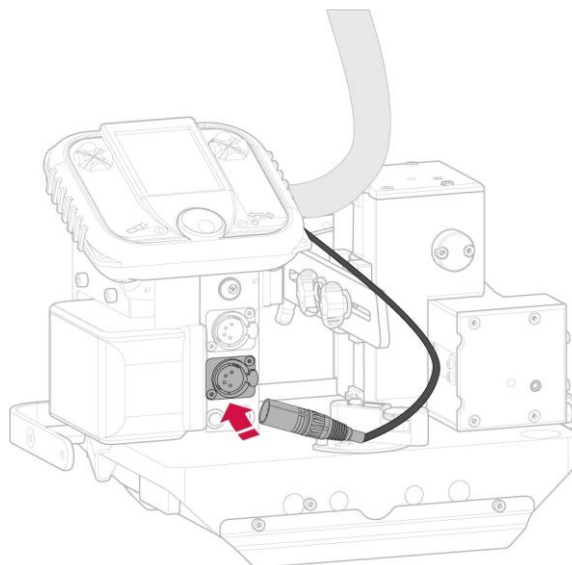

- 1) Connect the accessory cable to the appropriate connector. It is used to connect an accessory (motorized axis, communication box, etc.).

5.3 To connect the arc detector

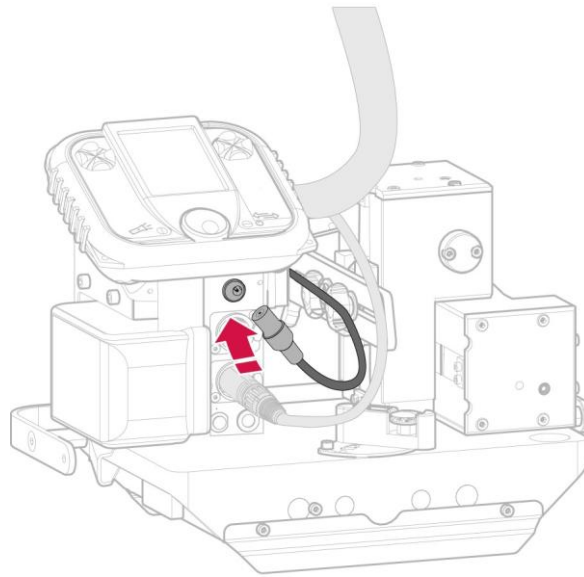

- 1) Connect the arc sensor cable to the socket.
- 2) The cradle movement is then synchronized with the arc. Initiate by pulling the burner trigger.

5.4 Turning the cart on and off

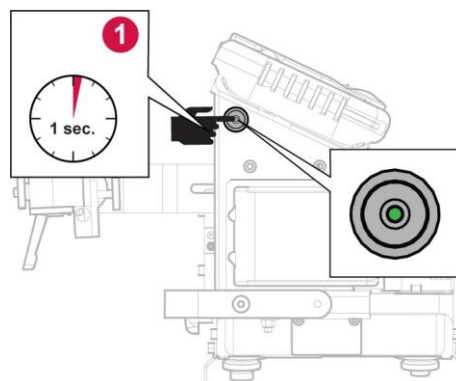

Starting the vehicle

- 1) Press the button to turn on the unit. The LEDs and the screen light up.

Switching off the vehicle

- 1) Press and hold the start button (3 seconds) to switch off the device. The LEDs and the screen go out.

6 CONTROL PANEL

6.1 Description of standard tower

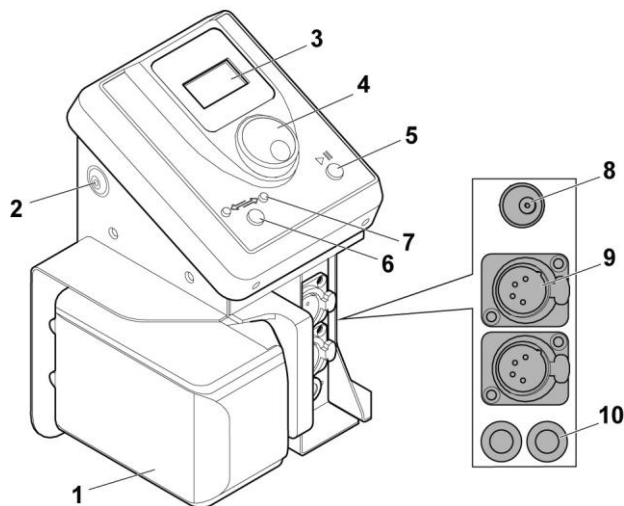

- **Battery (1):** supplies power to the device. The device is designed for operation with 18 V DC (3 A) with a Li-ion battery (standard 5 Ah/h) or an external power supply.
- **Illuminated ON/OFF button (2):** for switching the device on and off. There is a light indicator that indicates if the device is powered on.
- **Screen (3):** for configuring and controlling the device.
- **Rotary/click knob (4):** to scroll through the menus and to select the different operating settings.
- **Cycle start/pause button (5):** to start or stop the cycle.
- **Direction change button (6):** to change the direction of movement of the carriage.
- **Direction indicator (7):** to indicate trolley direction. The LED flashes when the cycle is running.
- **Welding arc sensor socket (8):** for connecting a welding arc sensor located on the torch holder. The movement of the carriage is then synchronized with the arc triggered by the torch trigger.
- **Accessory connector (9):** for connecting an accessory (runner, sensor, lamp, etc.).
- **Burner trigger connection (10):** For connecting a trigger control cable to the burner. The welding arc is then synchronized with the carriage movement triggered by the cycle start button on the console.

6.2 Description of the Programmable Tower and Remote Control

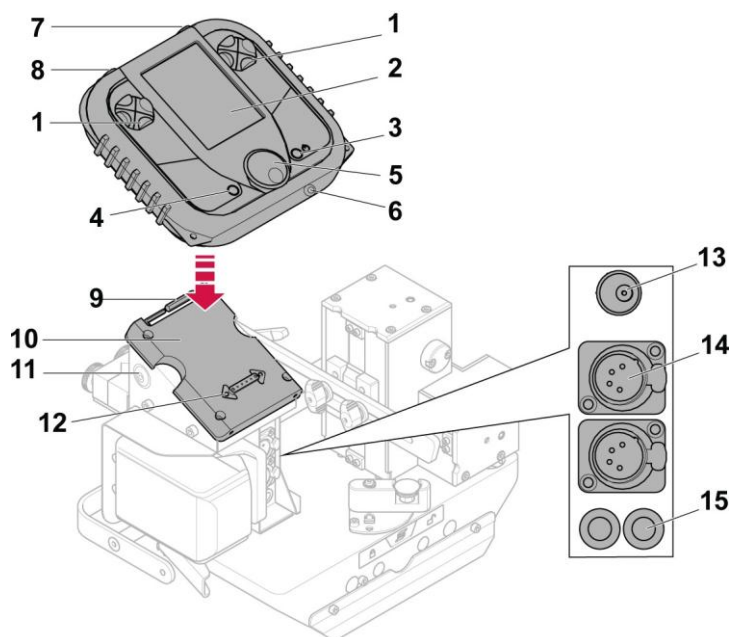

- **Direction arrows (1):** Changes the various device settings.
- **Screen (2):** shows the different menus and settings for the device.
- **Ignition and direction change button (3):** to switch on the remote control. On the Main page, a short press opens the Oscillation page (if activated); a long press changes the direction of the carriage movement. Returns to the previous page in configuration pages.
- **Light button (4):** turns on the light on the back of the remote control.
- **Rotary/click wheel (5):** Navigation through the menus and selection of the different operating settings.
- **Charging socket (6):** Connects a charger to charge the remote control.
- **Right configurable trigger (7):** default to start the cycle (= cycle start).
- **Left configurable trigger (8):** default to start a test cycle without moving the carriage and without starting the arc (= pre-cycle).
- **Tools (9):** Two Allen keys are provided for adjusting the mechanical slide elements.
- **Pairing and charging station (10):** for storing, charging and pairing the remote control.
- **Illuminated ON/OFF button (11):** for switching the trolley on and off. An indicator light indicates if the device is powered.
- **Direction LEDs (12):** When the remote control is pulled back, the two LEDs indicate the direction in which the cradle is moving.
- **Welding arc sensor socket (13):** for connecting a welding arc sensor located on the torch holder. The movement of the carriage is then synchronized with the arc triggered by the torch trigger.
- **Accessory connector (14):** for connecting an accessory (runner, sensor, lamp, etc.).
- **Burner trigger connection (15):** For connecting a trigger control cable to the burner. The welding arc is then synchronized with the carriage movement triggered by the cycle start button on the console.

6.3 Description of the standard tower interface

6.3.1 Main Screen Display

This page can be accessed after switching on the stacker by pressing the start button ("[Description of the standard tower](#)", page 16) located on the side of the tower.

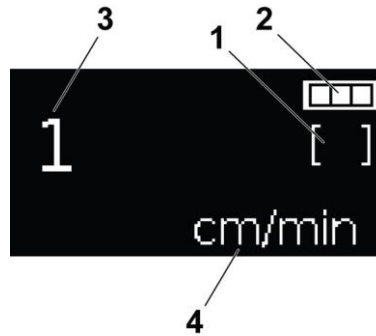

- Vehicle status (1)
 - []: Programmable mode disabled
 - [P]: Programmable mode activated



NOTE!

The programming modes may vary depending on the cart model.

- Battery level (2)
- Welding speed indicator (3), changeable in cycle:
The selection of the number of decimal places after the point is configurable.
- Welding speed unit (4).



NOTE!

In vertical positions and with a certain mass on board, the distance traveled may deviate from the guidelines.

6.3.2 Access to product information

This page can be accessed by pressing and holding the rotary knob ("[Description of the standard tower](#)", page 16) for 2 seconds when the ESAB logo is displayed when the trolley is switched on.

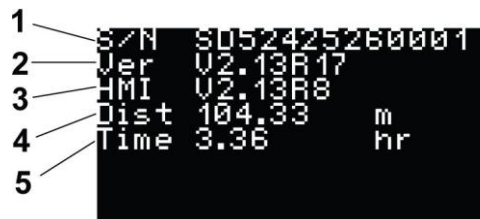

- ESAB serial number (1)
- Carriage version (2)
- Interface version (3)
- Distance traveled (4)
- Undervoltage counter (5): Increment of the time since the device was switched on (in hours).

6.3.3 Accessing the Advanced Settings Menu

This page can be called up by holding down the rotary knob ("*Description of the standard tower*" , page 16) and

Press and hold at startup after the product information screen is displayed until "Password" is displayed, then release.

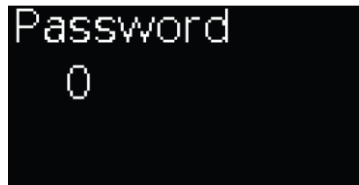

- Enter the password (using the dial):
 - Customer: 73

Then click the dial to access the Advanced Settings menu:

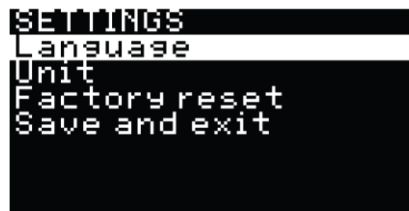

- Select the desired configuration using the dial and then click to access the selection.
- You select the value with the rotary knob and then click to confirm your selection by returning to the menu page.
- When done, click one of the two buttons ("*Description of the standard tower*", page 16) to save and return to the main interface view.
- Possible settings are:
 - Reduction 1
 - Step width: 1
 - Min.: -10000
 - Max.: 10000

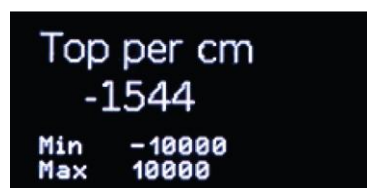

TRACFINDER RAIL skid reduction table:

Version	"Top per cm"
Rail R: 588	-1544



WARNING!

If these settings are changed, the maximum permissible speed must also be changed.

- Reduction 2: for a TRACFINDER RAIL wagon, the value is 0.
- Max. Speed (in cm/min or in inch/min) (speed corresponds to the "non-welding" speed):
 - Step width: 0.1
 - Min.: 0.1
 - Max.: 1000.0

Version	“Top per cm”
Rail R: 588	Max.: 200.0 (if cm/min)/80.0 (if inch/min)

```

Max speed
180.0 cm/mn
Min 0.1
Max 1000.0

```

- Sheet metal sensor: only for TRACFINDER WHEEL type carriage.
- This option prevents the carriage from moving when no magnetic metal surface is detected under the base.
- Language versions:
 - Fr = 0
 - En = 1
- Unit: Selection of the different units of measurement.

```

METRIC
1 cm/min
0.1 cm/min
1 inch/min
0.1 inch/min
0.05 inch/min

```

- Restore factory settings: The software is restored to factory settings.

```

Factory reset
OFF

```

- Click on one of the two buttons (["Description of the standard tower"](#) , page 16) to save and return to the main interface view.

6.3.4 Time schedules

This page can be called up by clicking on the selector wheel (["Description of the standard tower"](#) , page 16).



Pressing the rotary knob will take you to the Programming page (1). Click the dial to select the programming mode.

- “ON” programming (1): The trigger cable must be connected to a welding power source in 2-stroke mode (2T).
- “OFF” programming (2): The welding current source is in 4-cycle operation (4T). The cart start can be controlled manually by the welder (pressing the “On” button) or automatically by the arc detection of the torch (if the sensor is connected and selected).

To switch from one option to another, simply turn the dial. Then confirm by clicking on the wheel.

- [P]: Programmable mode activated
- []: Programmable mode disabled

6.3.5 Programmable mode enabled “ON” [P]

By selecting the programming mode “ON” (*“Programming”*, page 20).

Turn the dial to navigate through the different setting options.

- Delay time of the welding control before the carriage moves forward during the defined time.



Click on the icon to change the following parameter:

- Delay time before welding (in seconds): 3.0
 - Step width: 0.1
 - Min.: 0.1
 - Max.: 3.0
- Welding length (length of the welding process at a speed preconfigured in the main view).



Click on the icon to change the following parameter:

- Welding length (in cm or inches depending on the selected setting): 5.00
 - Step width: 0.0.1/0.1/1 (depending on selected setting)
 - Min.: 0.00
 - Max.: 200.00
- Back burning (in programmable mode and at the end of the welding length, the carriage returns from the defined value)



Click on the icon to change the following parameter:

- Back burning (depending on the selected setting in cm or in inches): 3.0
 - Step width: 0.1
 - Min.: 0.0
 - Max.: 10.0

Arc burn back (Enable or disable welding during burn back).

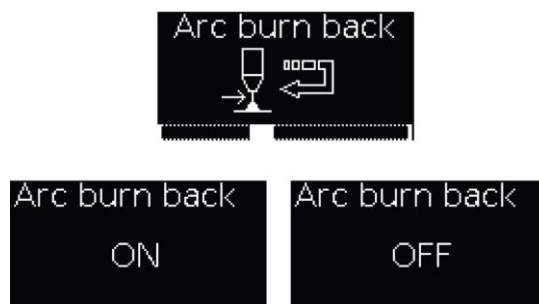

Click on the icon to change the following parameter:

- ON = 1: the “Trigger” relay output is active during crater return.
- OFF = 0: the “Trigger” relay output is inactive during crater return.
- Post-weld timer, continues the forward movement of the cradle for a defined time after the end of welding.



Click on the icon to change the following parameter:

- Delay time after welding (in seconds): 3.0
- Step width: 0.1
- Min.: 0.1
- Max.: 3.0
- Length without welding (forward movement without welding at maximum speed (with acceleration/deceleration ramp)).



Click on the icon to change the following parameter:

- Length without welding (in cm or in inches, depending on the selected setting): 5.00
- Step width: 0.0/0.1/0.1/1 (depending on selected setting)
- Min.: 0.00
- Max.: 200.00

- Repetition (number of repetitions of the programmed cycle (welding/non-welding)). Singularity if the value is equal to 0 = the repetition is infinite until the device is stopped by pressing the red button ("*Description of the standard tower*" , page 16).



Click on the icon to change the following parameter:

- Please retry again.
 - Step width: 1
 - Min.: 0
 - Max.: 99
- Number:



Click on the icon to change the following parameter:

- Number of decimal places after the dot in the display:
 - 0 = 0
 - 1 = 0.0
 - 2 = 0.00
- Delete cycles:

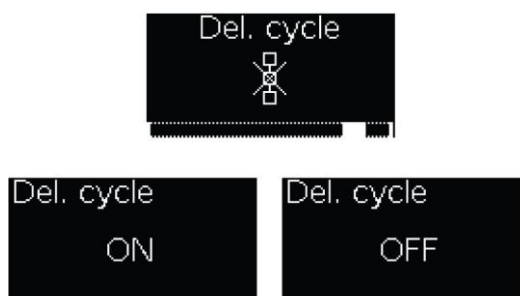

Click on the icon to delete the cycle.

6.4 Remote panel interface description

6.4.1 Remote control interface for extended HMI

The menu can be accessed by clicking on the rotary knob ("*Description of the programmable tower and remote control*" , page 17). The rotary knob is used to navigate through the different icons. The menu name is displayed at the bottom of the screen.

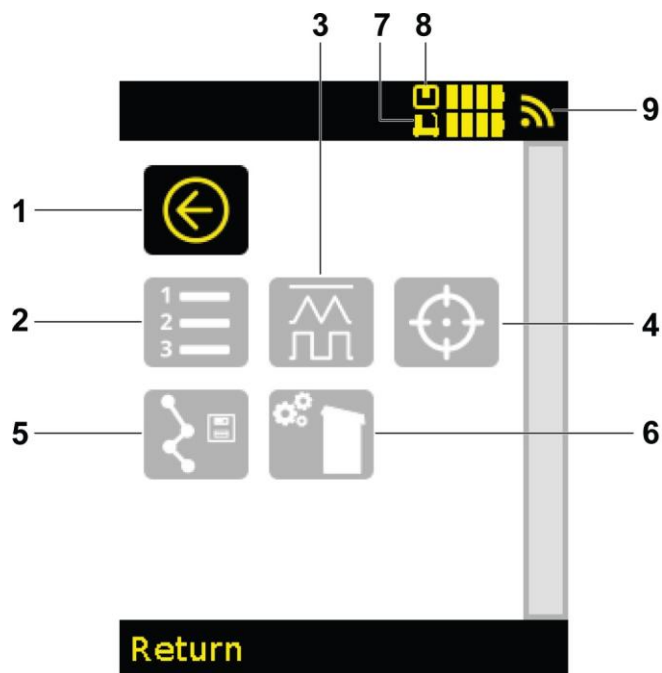

- **Back (1):** Returns you to the previous screen.
- **Processes (2):** To access the Job Management menu.
- **Cycle configuration (3):** accesses the configuration of welding cycles.
- **Reset (4):** Reset one or all axes on the carriage.
- **Route recording (5):** for learning points.
- **Machine configuration (6):** Displays the software and device information for the cart and accessories.
- **Battery (7 and 8):** Shows the charge level of the battery of the cradle (7) and the remote control (8).
- **Signal (9):** Shows the reception quality of the signal sent from the tower.

6.4.2 Transportation orders

This page can be accessed by selecting the “Orders” symbol (1) in the menu. The Jobs page is used to manage jobs by storing the settings associated with the movements of the cradle and the connected axes.

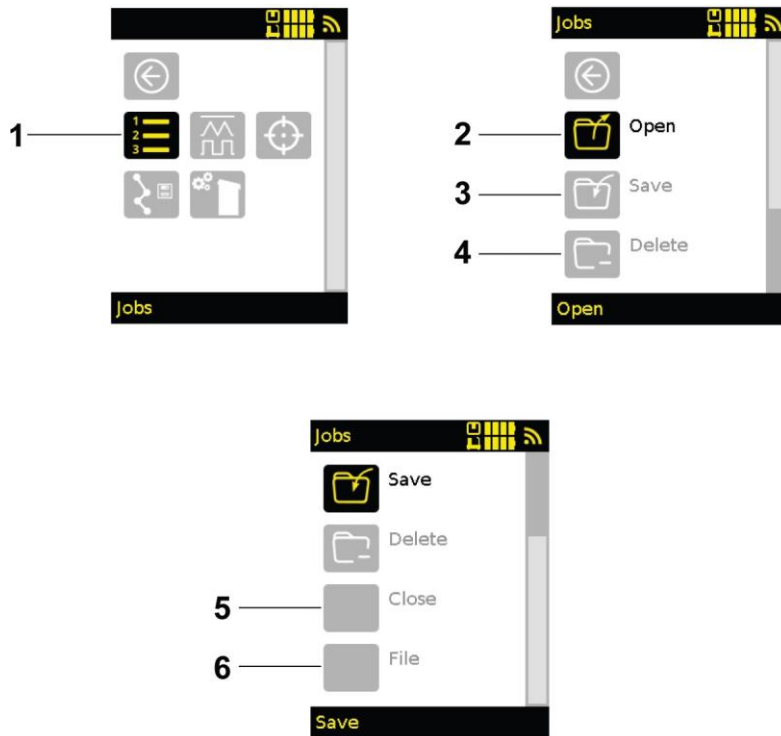

- **Open (2):** loads a job stored in the cradle memory.
- **Save (3):** saves the job according to all settings accessible in the cart memory.
- **Delete (4):** Deletes a saved job from the cradle memory.
- **Close (5):** closes a job (deletes the name of the active job shown at the top of the main view).
- **File (6):** Grant access to the Save Job submenu.

6.4.3 Archiving of orders

Archived jobs (or jobs to be archived) can be called up via the “File” symbol (1) on the “Jobs” page.

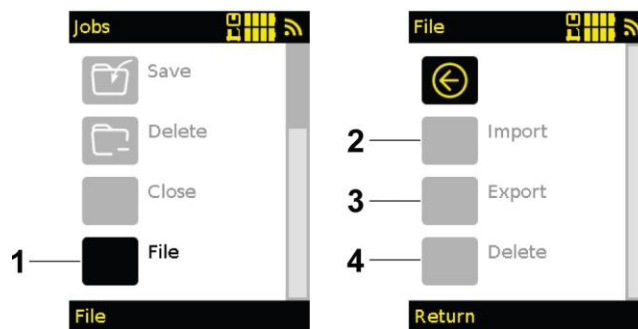

Archiving allows you to transfer orders from one cart to another by using the remote control for storage:

- **Import (2):** stores all cradle jobs in the remote control memory.
- **Export (3):** Displays when a backup has been made and loads the jobs stored in the remote control to the carrier.



WARNING!

The orders currently in the cart are overwritten.

- **Delete (4):** Delete the jobs stored in the remote control.

6.4.4 Cycle Configuration

This page can be accessed by selecting the “Cycle configuration” icon (1) in the menu.

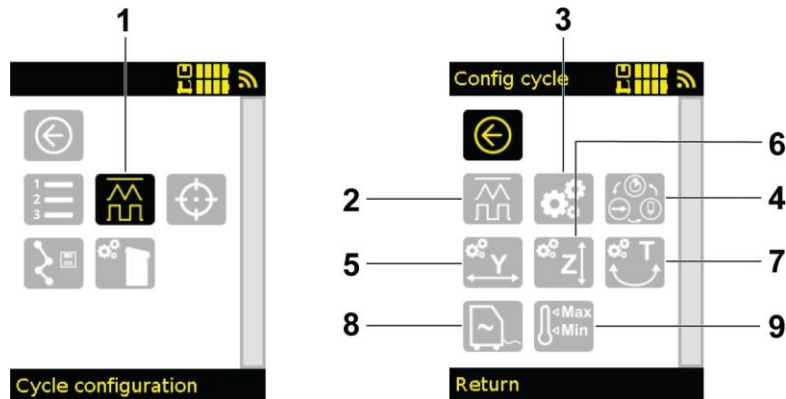

The “Config Cycle” page provides access to the configuration of the welding cycles to characterize the feed shapes, the settings associated with the device type, the configuration of the axes connected to the device or the programming of a welding sequence.

On the “Config cycle” page, symbols are displayed according to the connected equipment. The above page represents a carriage with 3 axes (Y, Z and T) and a communication box connected to a power source. When the Y-axis is disconnected, the symbol (6) corresponding to the Y-axis disappears.

For a sales record (*“Carriage jobs”*, page 24 and *“Archiving jobs”*, page 25), all settings in the “Cycle configuration” menu are saved in the job.

- **Cycle form (2):** is used to call up the different welding and oscillation modes.
- **Setting (3):** gives access to the general cycle settings.
- **Cycle programming (4):** is used to create a welding program with different tools.
- **Transverse axis configuration (5):** Used to configure the settings of the transverse axis (Y-axis) with or without oscillation.
- **Vertical axis configuration (6):** is used to configure the vertical axis (Z-axis) and elevation servo control settings.
- **Angular axis configuration (7):** used to configure the angular axis (T-axis) settings with or without oscillation.
- **Power source settings (8):** used to configure the power source settings (only visible if a communication box is connected).
- **Limits (9):** to set limits for different settings.

6.4.5 Cycle Shapes

This page can be accessed by selecting the “Cycle form” icon (1) on the “Cycle setup” page.

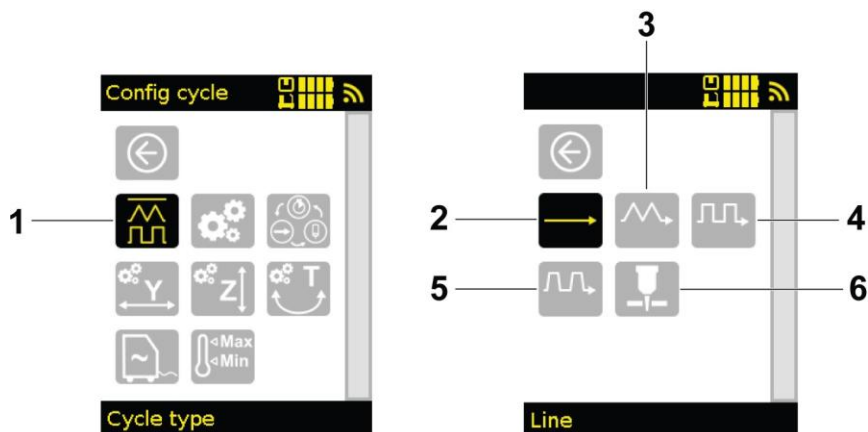

- **Tension or straight cord (2):** Welding mode for producing one-piece seams without vibration.

The following oscillation modes are available if the cradle has at least one electric Y-runner or T-oscillator. When both are connected, select the axis(es) you want to oscillate with.

- **Triangular vibration (3):** First synchronized oscillation mode. The cradle moves while traversing the pendulum axis. If a timeout is set, the carriage stops during oscillation.
- **Square oscillation (4):** second synchronized oscillation mode. The cradle moves forward, i.e. along the chamfer edges, during the timeout. When crossing, the cradle does not move forward.
- **Trapezoidal vibration (5):** Basic oscillation mode. Sweeping is not synchronized with the cradle movement, which remains constant.
- **Plasma (6):** This mode allows plasma cutting via a trigger cable connected between the turret connector and the plasma source.

6.4.6 Welding

This page can be accessed after selecting a cycle form ("*Cycle forms*", page 26). From the Main page, toggle between the pages to access the Welding screen.

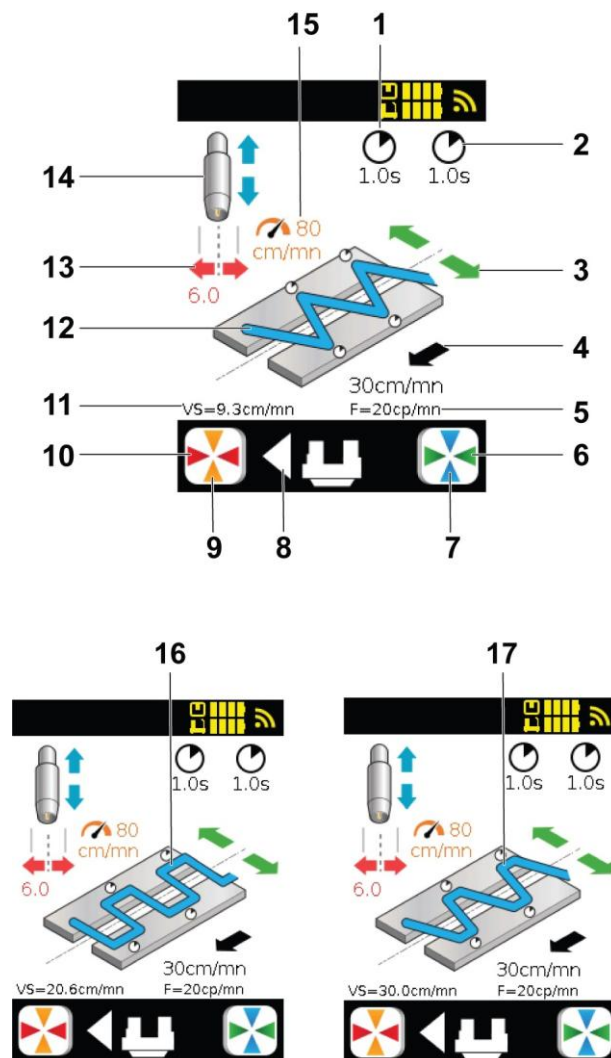

Three different sides depending on the type of welding selected: "Triangle step" (12), "Square step" (16) or "trapezoidal stage" (17). In the different displays, only the welding sequence diagram changes.

- **Welding flow chart (12), (16) or (17):** to display the type of welding in progress.

- **Direction of movement of the carriage (8):** to indicate the direction of movement of the carriage, represented by a triangle. Green arrows move the vibration center for the welding torch.
- **Orange arrows (9):** to change the orange element around the welding flow chart (15): Increases or decreases the oscillator speed.
- **Red arrows (10):** to change the red element around the welding flow chart (13): Increases or decreases the oscillation amplitude.
- **Blue arrows (7):** Changes the blue element around the welding sequence diagram (14): Raises or lowers the welding torch.
The cradle position is displayed when an axis zero point has been taken (see "*Axis Guidance (Manual Operation)*" , page 39)
- **Green arrows (6):** Activates the green arrows around the flow chart of the machine process (3): Moves the vibration center for the welding torch.
The cradle position is displayed when an axis zero point has been taken (see "*Axis Guidance (Manual Operation)*" , page 39). Direction of movement of the trolley.
- **VS (11):** indicates the welding speed.
- **F (5):** Displays the oscillation frequency (in strokes per minute). When the power source is connected, this information is no longer displayed, but the welding settings.
- **Speed (4):** Changes the speed of the cradle movement.
- **Timer (delay) (1):** to change the left timeout (depending on the direction the cradle moves).
- **Timer (delay) (2):** to change the right timeout (depending on the direction the cradle moves).

**NOTE!**

By default, only one timer is visible that is the same for both sides. To have both timers, activate "Double dwell time" in the settings (see "*Settings*" on page 29)

6.4.7 Plasma cutting

In plasma cutting, a specific cycle can be used to simplify operation, as the start height does not match the cutting height.

The torch is primed in contact with the metal sheet and lifted to a certain height for initiation (1), then the arc is started and advanced to this height for a certain time (1). It then falls back to cutting height (1).

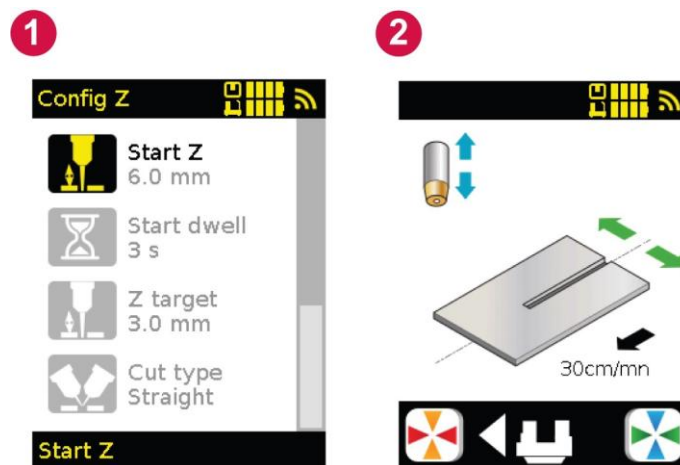

If you are performing a bevel cut, you can make a bevel selection under "Cut type" (1). This means a lower start and cutting height, depending on the angle.

**NOTE!**

When chamfering, it is also possible to leave the straight cutting mode and select the desired heights directly.

This page can be accessed after selecting "Plasma" (see "*Cycle Forms*" on page 26). On the Main page, you must switch pages to access the Plasma Sectioning screen.

This page has the same layout and therefore the same description as the Welding page without the oscillation settings, see *Welding* section, page 27.

6.4.8 Preferences for

This page can be accessed by selecting the "Settings" icon (1) on the "Cycle Setup" page.

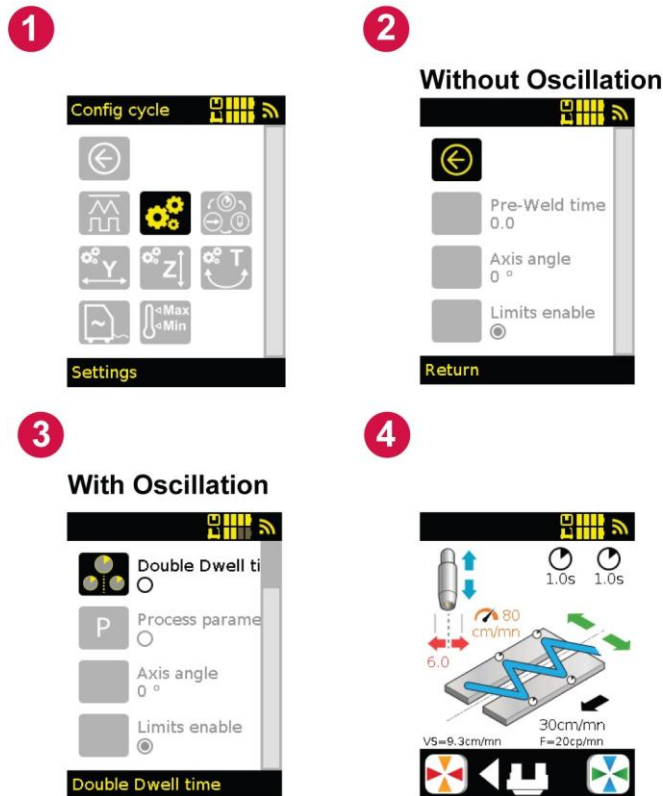

The Settings page allows access to the general settings of the cycle.

- **Pre-welding time (2):** is used to delay welding relative to the carriage on a continuous seam without oscillation.
- **Axis angle (2):** used to create a virtual reference for the slides. Movement and oscillation occur within the specified angle (angle between -90° and 90°).
- **Activate limits (2):** Enable user limits.
- **Double the dwell time (3):** Enables the ability to change the right and left dwell time independently of each other.

**NOTE!**

In the case of a simple timeout, only the information 1.0 s remaining time delay is displayed. In the event of a double timeout, the information 1.0 s time delay is displayed on the left and right.

- **Process settings (3): another** method for setting up oscillation welding.

**NOTE!**

The parameter is active when the field under the text is black; the parameter is inactive when the field is white. The “Process Settings” parameter is inactive and the “Active Limits” parameter is active.

6.4.9 Time schedules

This page can be accessed by selecting the “Cycle Programming” icon (1) on the “Cycle Setup” page.

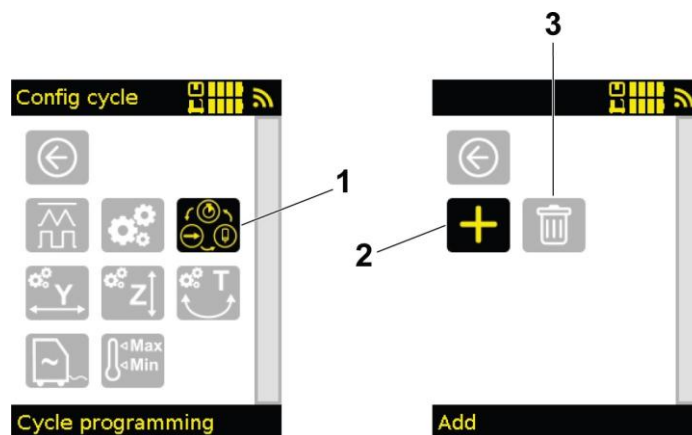

The programming module is programmed according to the principle of step-by-step programming (max. 16 steps). To start programming, a first step must be added by pressing the + button (2) to select the first cycle function. A cycle is deleted with the “Remove all” button (3). For example, the following sequence corresponds:



- 100 mm movement, without welding, at a predefined feed rate (not changeable in cycle) (4).
- 1 second delay before welding (5).
- 50 mm movement with welding torch n°1, at the speed defined by the “Job” (possibly changeable by the user in the cycle) (6).

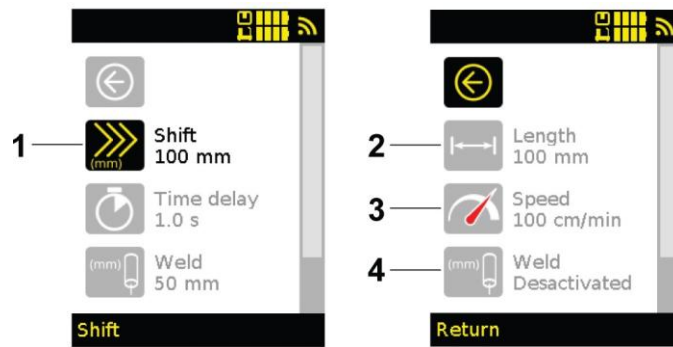

A cycle consists of a series of steps corresponding to a predefined function. For each selected level, the settings described in this section are required.

- **Displacement (1):** The carriage moves over the defined length (2) at the defined speed (3) with or without welding arc (4).



NOTE!

When welding is activated, the cradle speed is fixed and cannot be adjusted during the cycle. To change them during the cycle, select a Welding function.

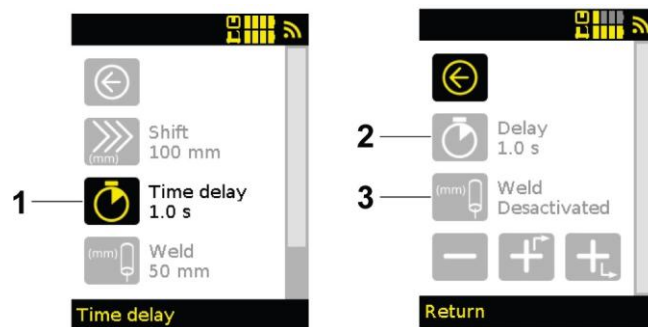

- **Time delay (1):** The cradle is stopped during this step (2) for the set time while welding (3) is activated or deactivated.

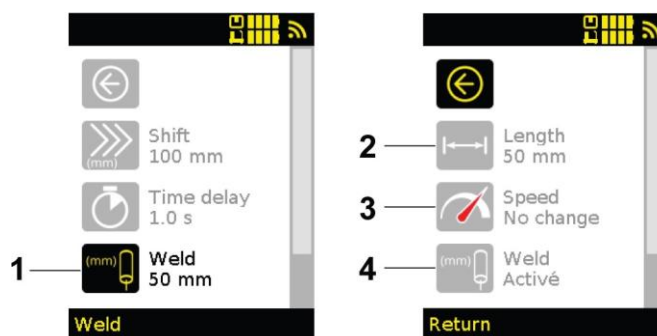

The welding function is used to set the length of the weld bead to be produced with the selected torch (default torch n°1).

- **Welding 1 (1):** The carriage travels the defined length (2) with illuminated welding arc for torch n°1 (4).
- **Speed (3):** “No change” can be selected. In this case, the speed can be adjusted using the rotary knob. If a value is set, this speed is automatically set at the start of welding, but can be changed later.

**NOTE!**

The trigger cable must be connected.

If the carriage is equipped with two trigger connections on the turret, a distinction can be made between the actuation of the two burners. “Weld 1” for the left bushing, “Weld 2” for the right bushing or “Weld 1+2” for both simultaneously.

Other configurations can be selected if a second flashlight is linked to the device and connected via a second trigger cable:

- **Welding 2:** The carriage moves with illuminated welding arc for torch n°2 along the defined length (2). The trigger cable must be connected for burner n°2. This is intended for intermittent welding alternating with the installation of two torches.
- **Welding 1 + 2:** The carriage travels over the defined length (2) with illuminated welding arc for torch n°1 and n°2. The trip cable must be connected for burners n°1 and n°2.

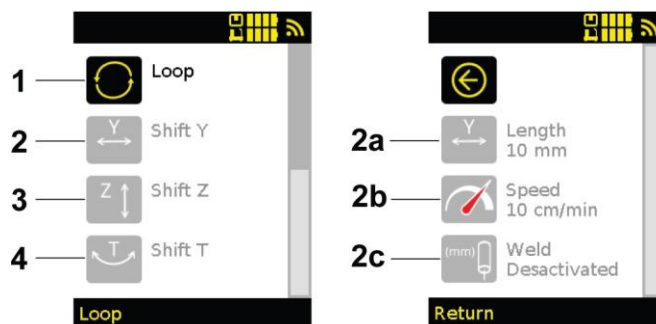

It is possible to add additional functions to the axes connected to the machine and repeat the cycle.

- **Loop (1):** End of the program step that activates a repeat function. You only need to set the number of cycle repetitions. If the value is 0, the loop is unlimited until the cycle is stopped voluntarily.

**NOTE!**

By default, the cycle ends at the end of the last step if loopback is not active.

- **Displacement Y (2):** The torch moves along the defined length (2a) along the linear Y-axis, at the defined speed (2b), with or without welding arc (2c).
- **Shift Z (3):** The torch moves along the linear Z-axis, over the set length, at the set speed and with or without welding arc.
- **Shift T (4):** The torch moves along the angle T-axis, with the set angle, with the speed and with or without welding arc.

A program can be changed by deleting or inserting a step in a cycle. Select a cycle phase and then select the icons at the bottom of the page.

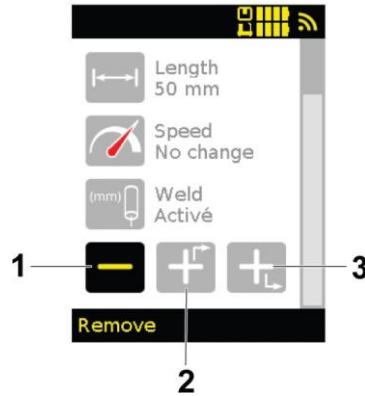

- **Delete (1):** The selected step.
- **Add before (2):** The selected step is a new function. You then only need to define the settings for this phase before returning to the cycle creation page.
- **Add after (3):** The selected step is a new function. You must then define the settings for this phase before returning to the cycle creation page.

6.4.10 Settings of the connected axes

These pages can be accessed by selecting the "Config. Transverse Axis" (1) to display the "Y-Config." page of the "Config. vertical axis" (3) to display the "Z-Config." page and the "Config. Angle Axis" (6) to display the "T-Config." page (identical to the "Y-Config." page) from the "Cycle Config." page.

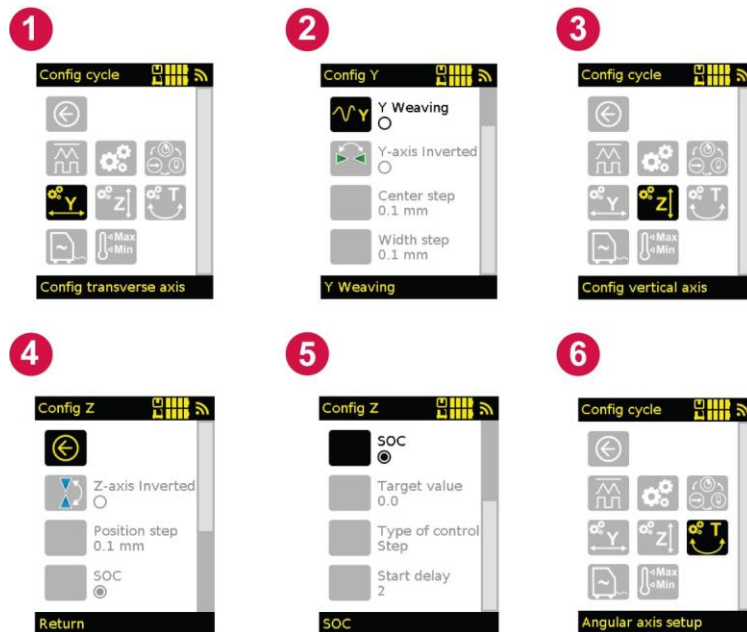

- **Y oscillation (2)/T oscillation:** activates or deactivates Y linear oscillation or T pendulum oscillation.
 - When activated: The oscillation settings can be changed.
 - When deactivated: The axis is considered an electric slide and only the position can be changed.

**NOTE!**

Disable an unused oscillation to simplify the MMI.

Activation is possible if a Y-runner and a T-pendulum oscillator are present. If there is only one axis, it is automatically active when an oscillation shape is selected.

- **Y-axis inverted (2), Z-axis inverted (4) or T-axis inverted:** Inverts the direction of the axis motion controls. In standard mode, left and right are defined for the Y and T axes according to the direction the cradle moves. For the Z-axis, the up arrow raises the bracket and the down arrow lowers the bracket.

**NOTE!**

This is only displayed if an electric linear actuator is connected.

- **Middle stage (2):** Step width per pulse. A single pulse advances it by 0.1 mm.
- **Position step (4):** Step width per pulse. A single pulse advances it by 0.1 mm.
- **SOC (Stick-Out Control) (4):** Enables or disables the Z-axis servo control. AVC is written in TIG.
- **Specified value (5):** Selection of the servo control setpoint. If the value is 0, the target value is set automatically by measuring at the beginning of the arc. If the value is greater than 0, this is the setpoint setting.
- **Ass. Type (5):** Select the servo type.
Step: By pressing the up and down buttons on the Z-slide during welding, the user can change the set point by 1 A (or 0.1 V in TIG).
Jog: By pressing the up and down buttons on the Z-carriage during welding, the user can directly change the position of the Z-carriage, which is then the new target value.
- **Pre-ACQ time (5):** used to set a time (in seconds) before starting the Z-servo. Corresponds to pre-gassing and arc stabilization.

The settings are displayed as checkboxes. If there is a black dot, the setting is active.

**NOTE!**

Additional servo settings and communication box configuration are accessible in the hidden menus.

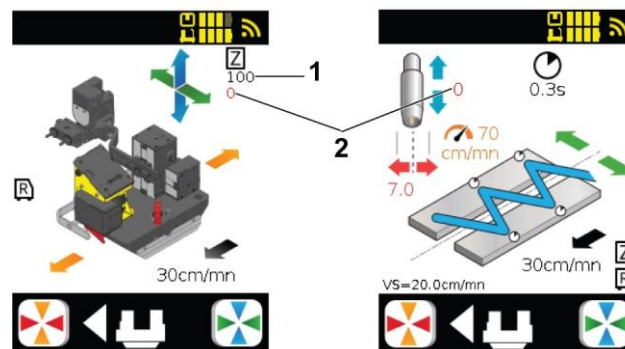

- **100 (1):** Objective & Targets
- **0 (2):** Value is read in real time. In the hidden menu, the variable “Display data directly” must be checked.

**NOTE!**

If you use a straight path, the value in red is the actual value. If the continuity oscillates, the value is averaged over a period of time and then displayed.

6.4.11 Limits

This page can be accessed by selecting the “Limits” icon (1) on the “Cycle setup” page.



NOTE!

This page is useful to stay within the scope of a DMOS.

For the limits to be active and the limit logo to be visible, the checkbox on the Settings tab must be checked.

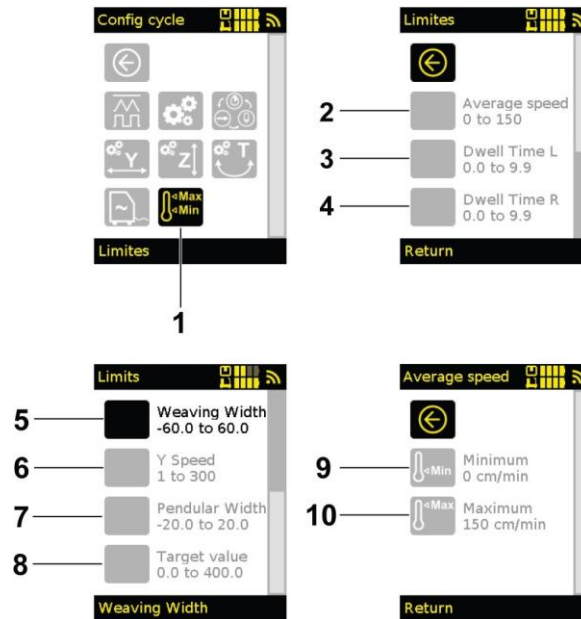

- **Average speed (2):** is used to select a minimum (9) and a maximum (10) for the operator adjustable value of the movement speed.
- **Dwell time L (3) and Dwell time R (4):** to select a minimum and maximum value for the time delays left (L) and right (R) when oscillation and double time delay are activated.
- **Weaving width (5):** Select a minimum (9) and a maximum (10) value for the oscillation amplitude.
- **Y-speed (6) and pendulum width (7):** When the communication box is connected, you can select a minimum and a maximum for your welding settings (not possible with all power sources).
- **Specified value (8):** If a communication box or analog box is connected, a minimum and a maximum for the servo setpoint are selected when the slave function is activated.

6.4.12 Zero point setting

This page can be accessed by selecting the “Origin” symbol (1) in the menu.

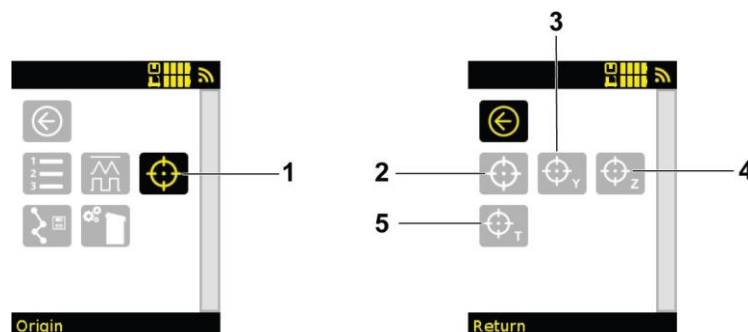

This menu resets all axes (2) or a single axis (3, 4 and 5) of the cradle to the home position.

At the end of the reset, the Y linear oscillator (3) and the T pendulum oscillator (5) are centered in the middle of their path. The electric Z-carriage (4) returns to the previous position to limit the risk of collision.

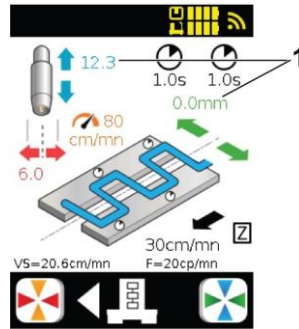

After resetting the axis, the position value for the axis travel in millimeters is displayed next to the corresponding arrow on the welding indicator (1).

6.4.13 Collaborative learning

This page can be accessed by selecting the “Save trajectory” icon (1) in the menu.

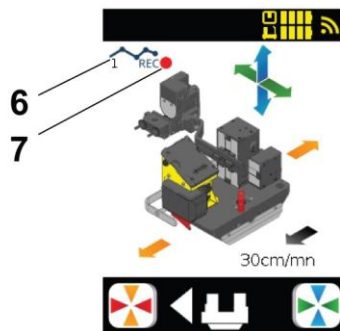
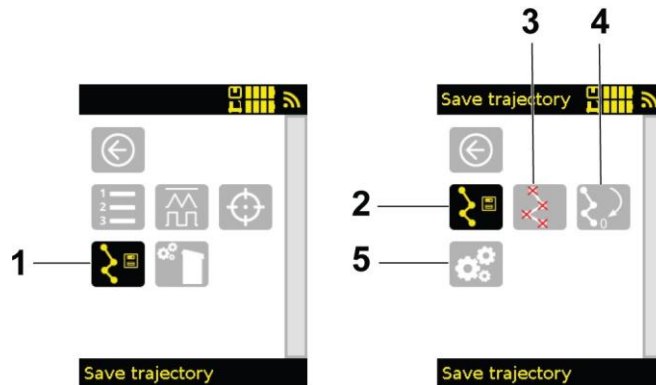

On this page the cradle can learn a number of points to define a path to follow (e.g. weld). A linear interpolation is performed between the points.

Icon (2): allows access to the Points learning page:

The “REC” logo appears at the top right of the screen (7). Use the arrows and the feed and positioning axes to move to the first point to be learned. Press the button at the top right of the controller (factory setting) to confirm the item.

**NOTE!**

Points are YZT coordinates for an X position, rail or track data.

Offset:

- It is possible to apply offsets to the web before starting a new weld (e.g. for multiple welding): The offset is applied to all points on the path.
- Offset can also be used for welding.
- Offset can be applied in any direction (YZT).

**NOTE!**

It is possible to store points in any order or add to a previously learned path: The points are automatically rearranged in the order where the distance between two points is the shortest.

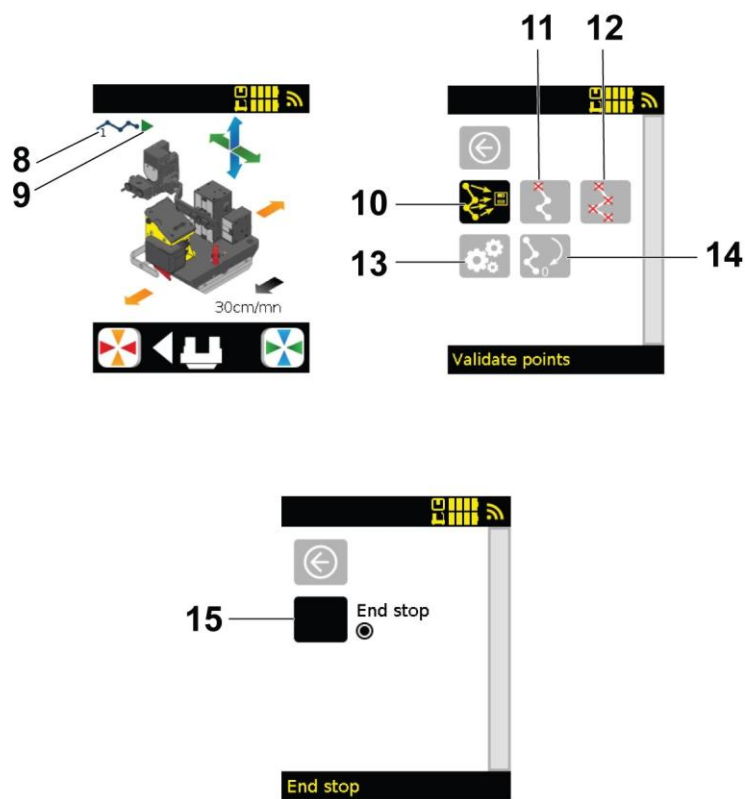

Repeat the process to validate multiple points.

The number of validated points appears at the top right of the screen (6).

Symbol (10): Confirm all points learned. At the top right of the screen, the “REC” logo (7) is replaced by a green arrow (9) and the number of learned points appears (8).

Symbol (11): Deletes the last learned point.

Symbol (12): Delete all points.

Symbol (14): Go to the first defined point.

Icon (13): is used to call up the page for the option to stop welding at the end of the web.

Symbol (15): Enable or disable the option to stop welding at the end of the web.

**NOTE!**

Points and paths cannot keep their position after restarting the truck.

In Learn mode, you can configure the two top buttons (1 and 2) of the remote control by pressing and holding the button you want to configure. Once the button is pressed and held, the screen offers a number of possible functions:

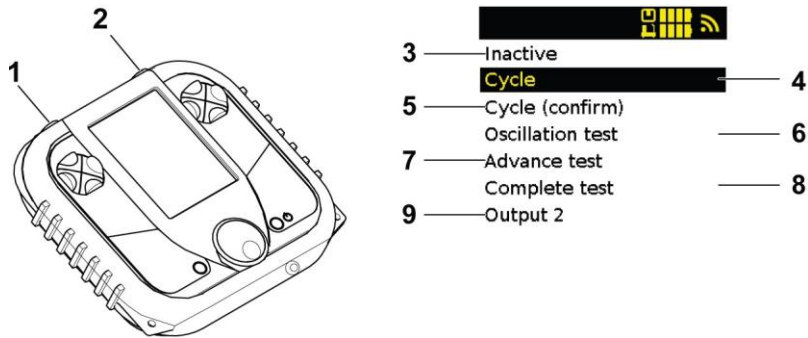

- **Inactive (3):** makes the button inactive.
- **Cycle (4):** Cycle start.
- **Cycle (confirm) (5):** cycle start by double-pressing (within 2 seconds). It is recommended to connect a torch to the sled with the trigger cable.
- **Oscillation test (6):** starts only oscillation, without cradle movement and without arc (if triggered).
- **Feed test (7):** starts cradle feed only, without oscillation and without arc. For example, to test the cycle programming.
- **Complete the test (8):** Starts feed and oscillation without arc.
- **Output 2 (9):** simulates a second output (special case).

NOTE!
If the learn mode is not activated, the buttons are set differently.

6.4.14 Machine Configurations

This page can be accessed by selecting the “Machine configuration” icon (1) in the menu.

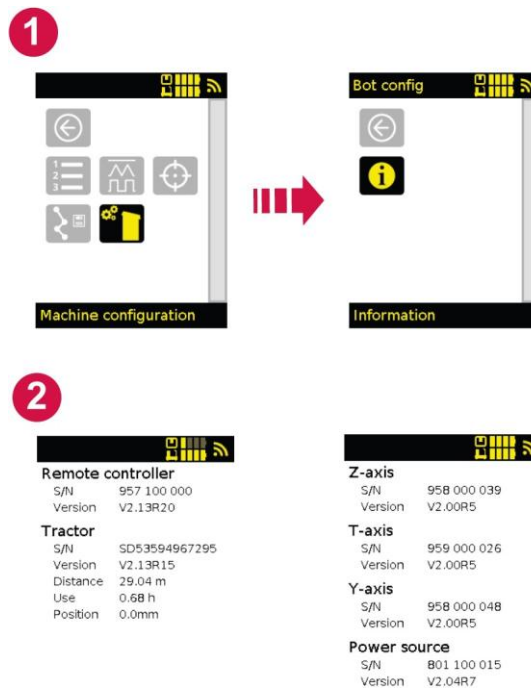

This page (5) shows the serial number and version of each component installed at the end of the carriage (5).

**NOTE!**

The beginning of the version number (before the R) between a slide and a remote control must be identical to be compatible. If the incompatibility message appears, you must update both the cradle and the remote control. These include, for example: V2.01R1 and V2.01R4 are two compatible versions.

This page (5) also shows the distance traveled and the time the cradle was in operation.

6.4.15 Axis guidance (manual mode)

This page can be accessed by pressing the button on the remote control.

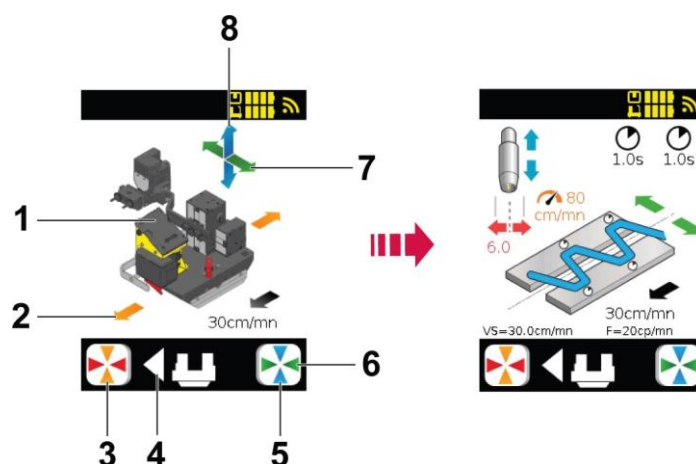

- **Machine flow chart (1):** shows the cradle.
- **Direction of movement of the carriage (4):** to indicate the direction of movement of the carriage, represented by a triangle.
- **Orange arrows (3):** Activates the orange arrows around the flow chart of the machine process (2): Moves the cradle forward or backward.
- **Blue arrows (5):** Activates the blue arrows around the flow chart of the machine process (8): raises or lowers the tool with the electric linear slide Z.
- **Green arrows (6):** Presses the green arrows around the flow chart of the machine process (7): Extends or retracts the tool using the Y-linear electric slide.

The control side for positioning the cradle and axes without welding.

This flow chart also shows which accessories are connected and detected by the trolley.

If three accessories are connected to a cradle and the cradle is controlled by a two-button multidirectional remote control, then you must use the button to toggle the sides to control the position of the linear Y-oscillator and the T-pendulum oscillator alternately with the colored arrows.

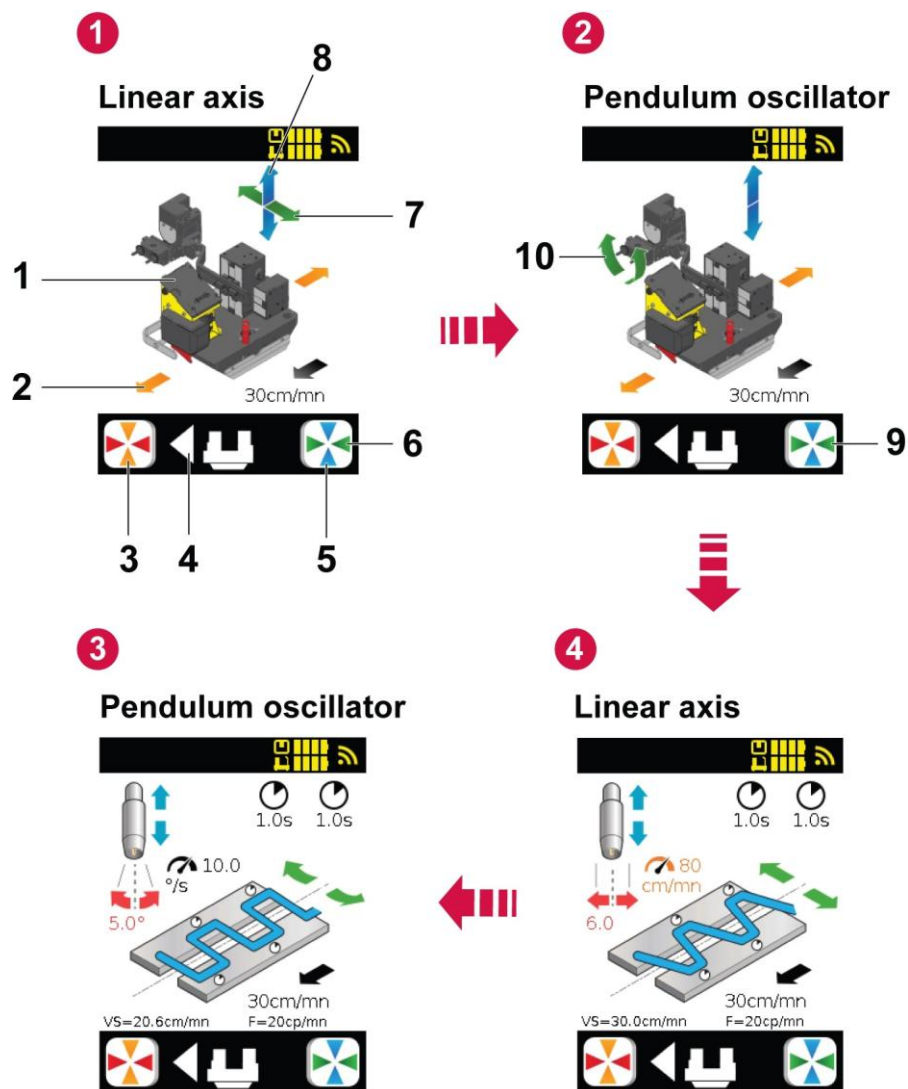

- **Machine flow chart (1):** shows the cradle.
- **Direction of movement of the carriage (4):** to indicate the direction of movement of the carriage, represented by a triangle.
- **Orange arrows (3):** Activates the orange arrows around the flow chart of the machine process (2): Moves the cradle forward or backward.
- **Blue arrows (5):** Activates the blue arrows around the flow chart of the machine process (8): raises or lowers the tool with the electric linear slide Z.
- **Green arrows (6):** Presses the green arrows around the flow chart of the machine process (7): Extends or retracts the tool using the Y-linear electric slide.
- **Green arrows (9):** activates the green arrows around the flow chart of the machine process (10): controls the tool using the electrical T-pendulum oscillator.

6.4.16 Role of the user

This function makes the cycle configuration pages accessible only to certain persons and allows only operators (users who have not logged in) access to job opening (1), resets (2), path recording (3) and cart information (4). This function can be turned on or off in the “Advanced Cart Configuration” menu (see “Advanced Cart Configuration” on page 43).

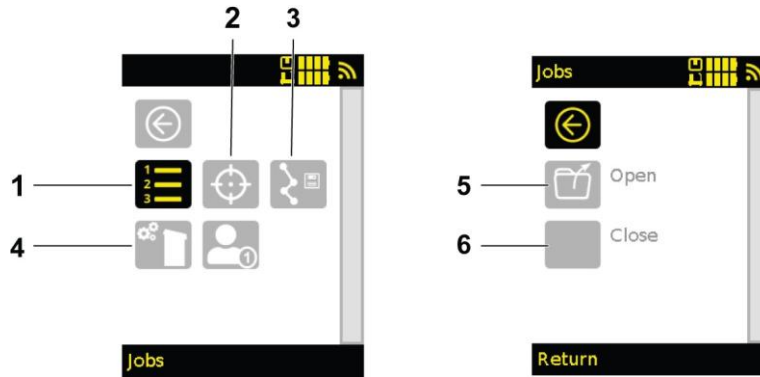

In the “Processes” tab (1), you can only open (5) or close (6). It is not possible to save, delete or access archives.

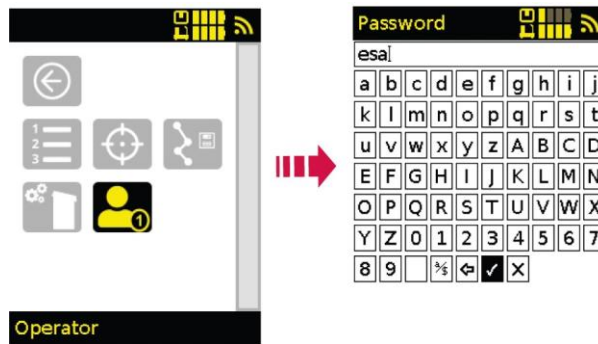

To access the rest, click on the sign. A numeric keypad appears, then enter the “esa” code and confirm. This will switch to the “Supervisor” mode.

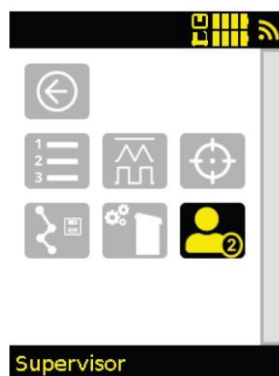

To return to the previous mode, click on the symbol.

NOTE! When the cart or remote control is turned on or off, the system automatically switches to operator mode.

6.5 Switching the remote control on, pairing and off

6.5.1 Switching on and off

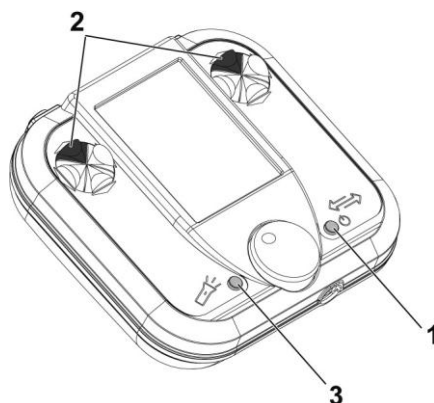

Starting up the remote control

- 1) Press and hold the start button (1) to turn on the remote control.

Switching off the remote control

- 1) When the car is switched off, the remote control will not be able to communicate with the car. After the waiting time, the remote control switches off automatically.



NOTE!

You can force it by pressing both buttons (1) and (3) simultaneously.



WARNING!

If the machine becomes unstable, it can be stopped using the remote control.



WARNING!

If the remote control is turned off during a cycle, the cycle stops. You can also turn off the remote control and leave the cart on, which will drain the cart's battery.

Always check the LED on the cradle power button (1).

6.5.2 Pairing the remote control

Only when using a remote control with a cart for the first time, when using a new remote control or cart, or when using a remote control from another cart.

- 1) As soon as the screen lights up after turning on the remote control, press the two upper arrows (see *"On and Off"* on page 42) to start the automatic pairing process with the cart.
- 2) Place the remote control on the cart base to pair it.

- 3) Then, each time the remote control is turned on, it will be paired directly with the car.

**NOTE!**

Pairing the remote control overwrites the last pairing of the remote control. No data will be lost as all data is stored in the cart.

6.5.3 Button Configurations

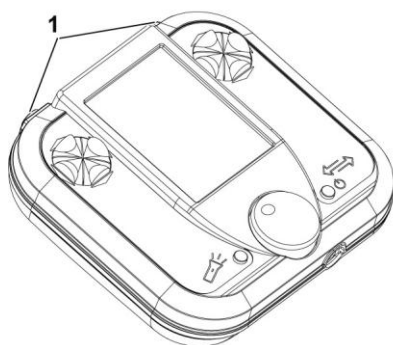

- 
- 2 — Inactive
 - 3 — **Cycle**
 - 4 — Cycle (confirm)
 - 5 — Oscillation test
 - 6 — Advance test
 - 7 — Complete test
 - 8 — Output 2

- 1) To access this menu, press and hold the desired button for at least 5 seconds (1).

- **Inactive (2):** makes the button inactive.
- **Cycle (3):** Cycle start.
- **Cycle (confirm) (4):** cycle start by double-pressing (within 2 seconds). It is recommended to connect a torch to the sled with the trigger cable.
- **Oscillation test (5):** starts only oscillation, without cradle movement and without arc (if triggered).
- **Feed test (6):** starts only cradle feed, without oscillation and without arc. For example, to test the cycle programming.
- **Complete the test (7):** Starts feed and oscillation without arc.
- **Output 2 (8):** simulates a second output (special case).

6.6 Advanced cradle configuration

The Advanced cradle configuration menu can be accessed at startup to configure special cradle settings.

Access to the password menu

- When switching on the remote control, press and hold the two lower arrows (1) when the display shows the logo, trolley and serial number.
- Enter password: esa

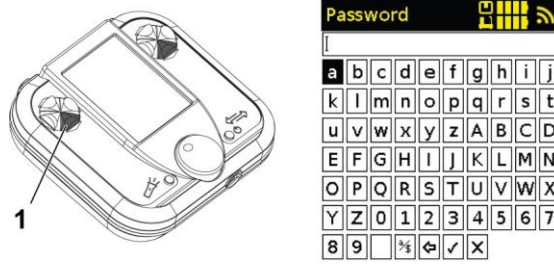

Access to the hidden remote control menu

1

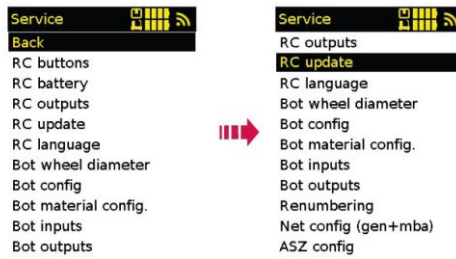

RC buttons

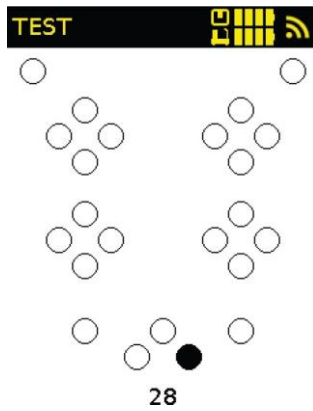

Remote control buttons test menu: to check whether a button is blocked (black circle) or not responding (the circle corresponding to the button clicked does not light up). To exit the menu, press the 2 down arrows on the top cross keys at the same time.

RC battery



Displays information about the remote control battery. **RC**

output

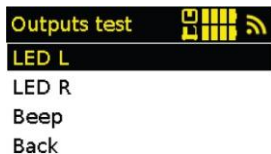

Tests the remote control outputs.

Update RC

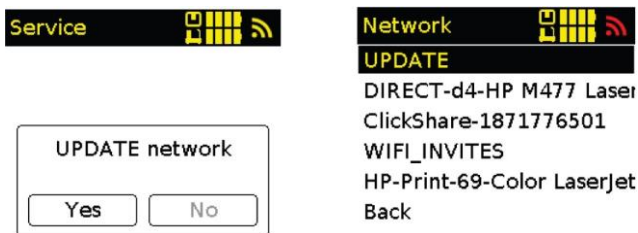

Open this menu to update the remote control. For complete software update instructions, see ["Software Updates"](#) on page 49.

Language RC



Select the language for the service menu.

Bot Config

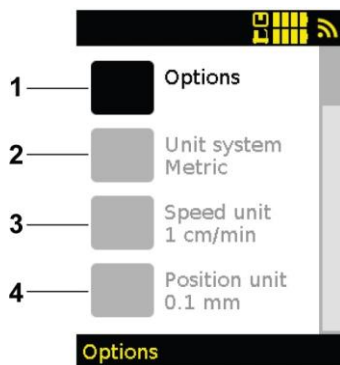

- **Options (1):** Enable or disable multiple functions. This allows the display to be cleaned up by removing functions that are not considered useful. This also makes it possible to use the “Limits” and “Users” functions that are not available as standard.
- **Unit system (2):** Select between metric (meters) and imperial (inches) units.
- **Speed unit (3): Selection of speed level.**
 - In metric: Selection of 0.1 or 1 cm/min.
 - In imperial: Select 0.05, 0.1 or 1 inch/min.
- **Position unit (4):** Selects the feedback accuracy of the cradle position (displayed on the POM oscillation page).
 - In metric: only 0.1.
 - In imperial: 0.005" or 0.01" selection.

Device configuration bot

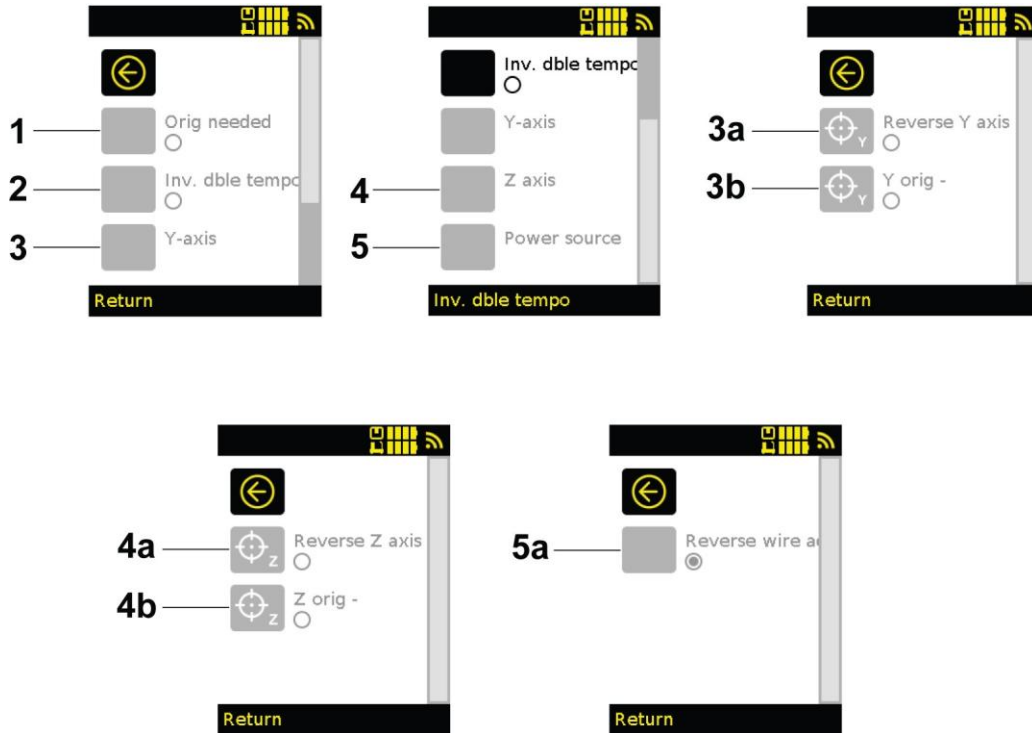

- **Origin required (1):** Requires the original connection at startup and blocks the cycle start if not done.
- **Inv. Double speed (2):** Inverts the position of the two timers on the oscillation display to double the time delay.
- **Y-axis (3) and Z-axis (4):** Y-axis backward (3) and Z-axis backward (4) are useful when the carriages are used in certain configurations where they are not mounted on a carriage. This will allow you to put them back in the right way if they were placed the wrong way round. To check this, disable “Y-Axis Reverse” and “Z-Axis Reverse” in this menu and in the menu and then check that the cradles move in the correct direction by pressing the movement buttons.
- **Y orig - (3b) and Z orig - (4b):** are used to reverse the direction of the original connection. Useful when there is a risk that the runner will come to rest in a certain direction.



WARNING!

By inverting the origin in z, the torch can be brought to the workpiece if it is too close.

- **Power source (5):** "Inv. Wire Feed" (5a) reverses the direction of wire feed when the corresponding buttons on the remote control are pressed (3).

Bot input

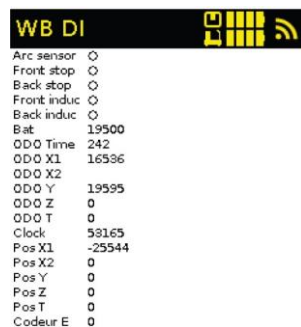

Displays information about the cradle and input status.

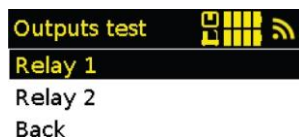
Bot output

Tests the carriage outputs.

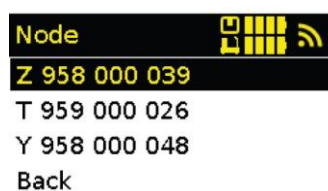
Renumbering

Reassigns a motorized axis. An axis can be set for Y-movement (left/right movement on a flat cradle) or Z-movement (vertical).

The serial number can be found on the axle label.

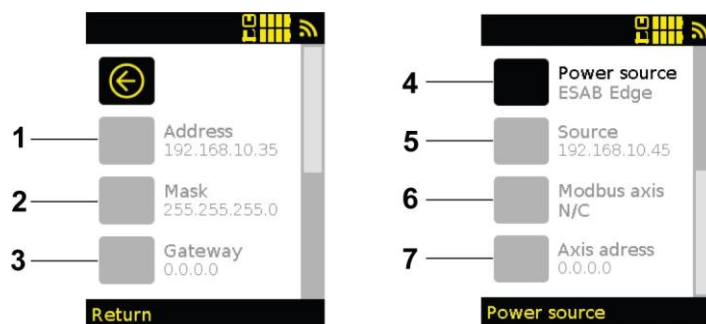
Configure network (gen + mba)

These pages configure the communication box used when a power source or suitable external axis is connected.

Enter the type of power source (4) and then the IP addresses of the communication box (1), subnet mask (2), gateway (3) and power source (5).

If you have a configurable external axis, enter its type (6) and IP address (7).

ASZ Config

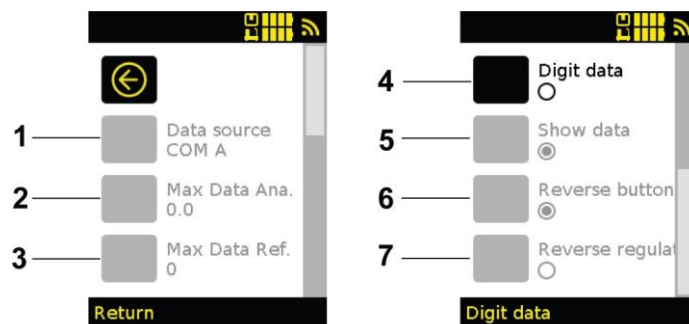

This parameter is only accessible when the servo is active.

These settings define the configuration of the servo system.

- **Source data (1):** is used to define the source from which control information is retrieved:
 - AVC: if the data comes from an analog box.
 - COM A: when the data comes from a communication box with a MIG (servo in amps) power source.
 - COM V: when the data comes from a communication box with a TIG (Servo in Volt) power source.
 - XLR: currently not in use.
- **Max Data Analog (2):** indicates the maximum value of the analog voltage returned from the power source.
This value is only useful if it is connected to an analog box for signal recovery.
- **Max. Data reference (3):** indicates the value of the actual voltage that corresponds to the maximum analog voltage sent from the power source.
This value is only useful if it is connected to an analog box for signal recovery.
- **Digit data (4):** Check if TIG is used (COM An or analog box with TIG).
- **Display data (5):** Shows the value of the servo variables read in real time below the target value on the home page. In oscillation mode, this value is displayed at the end of a period and corresponds to the average. This data is displayed in red.
- **Reverse button (6):** In servo mode “Step”, this button is used to reverse the direction of the setpoint change.
- **Reverse control (7):** Do not check when controlling with current (MIG-MAG). Check this when regulating with voltage (TIG/plasma).

6.7 Performing software updates

6.7.1 Updating tractor

- 1) Switch off the tractor.
 - Press the button to switch off the tractor (see *"Description of the standard tower"* on page 16) on the standard tractor.
 - Press the button to switch off the tractor (see “Programmable Tower and Remote Control Description” on page 17) on the advanced tractor.
- 2) Set up a mobile hotspot configured as:
 - Network name: Update Flags
 - Password: BOOT_BOT
- 3) Make sure that the system is active. Press and hold the On/Off button during the start-up process. Press and hold the button until the lights on the tower or on the simple interface start flashing.
 - For standard tractors, see “Description of standard tower” on page 16.

- For advanced tractors, see “Programmable Tower and Remote Control Description” on page 17.

4) Wait until the lights stop flashing.

5) Check on the information screen if the tractor software version has been updated.

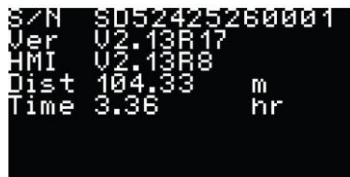

6.7.2 Remote control update

1) When switching on the remote control, press and hold the two lower arrows (1) when the display shows the logo, trolley and serial number.

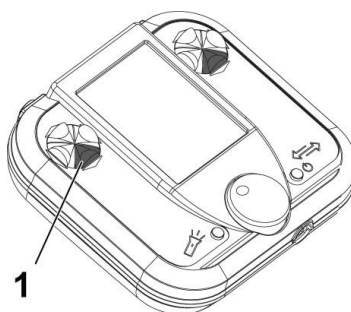

2) Enter the password “esa”.

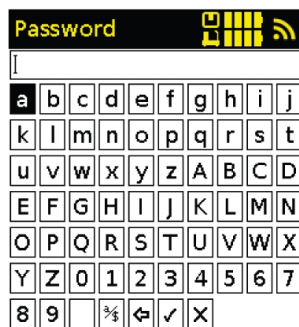

3) Select "RC Update" in the menu.

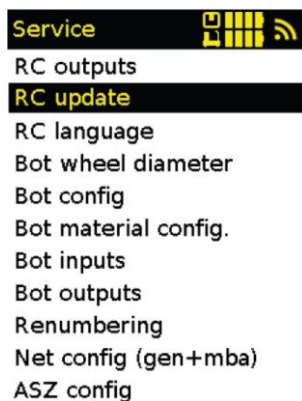

4) Update network:

- When the remote control is connected to the hotspot, press "YES".
- If the remote control is not connected, press "NO".



- If the mobile hotspot has been set up according to step 1, it can be selected directly without a password.
- If no mobile hotspot is available, a local Wi-Fi network can be selected. In this case, the WLAN password must be entered via the HMI interface.



5) When the remote control connects to a network, the update starts automatically.

- 6) Check the Information menu to confirm that the software version has been updated.



Remote controller	
S/N	957 100 000
Version	V2.13R20
Tractor	
S/N	SD53594967295
Version	V2.13R15
Distance	29.04 m
Use	0.68 h
Position	0.0mm

6.7.3 Update of accessories (communication box, axles, etc.).

- 1) Follow the same steps as when updating the cradle to update the accessories. Make sure that the accessory is connected to the accessory port during the update.
- 2) When the update is complete, check the information screen in the HMI to confirm that the software version has been updated.



T-axis	
S/N	959 000 026
Version	V2.00R5
Z-axis	
S/N	958 000 332
Version	V2.00R5
Y-axis	
S/N	958 000 232
Version	V2.00R5
Power source	
S/N	801 100 015
Version	V2.04R7

7 MAINTENANCE

**WARNING!**

The device must not be returned for repair or service with a possibly defective battery.

**CAUTION!**

Repairs and electrical work should be carried out by an authorized ESAB service technician. Only use genuine ESAB spare parts and wear parts.

**NOTE!**

Remove welding spatter and clean the magnets on the remote control regularly.

**NOTE!**

Clean the outside of the carriage and the adjustment components regularly. Clean the holder each time before inserting the battery.

7.1 Periodical maintenance checks

Every 100 hours of operation

- Clean the carriage and adjust the components.
- Cleaning the lower housing of the mobile stand
- Cleaning the support rollers
- Clean guide rollers and check for wear

Every 500 hours of operation

- Clean and lubricate moving parts
- Check the wear of the moving parts and replace any parts that show excessive wear.
- Carefully spray the circuit boards with dry air and check the connections

7.2 Instructions for maintenance and replacement of rails

Maintenance routines

- Clean the magnetic clamps regularly with a soft cloth and compressed air.

**WARNING!**

Safety goggles mandatory (danger of projectiles when cleaning the magnetic clamps).

**WARNING!**

Protective gloves mandatory (risk of crushing when handling equipment).

Replace the magnet

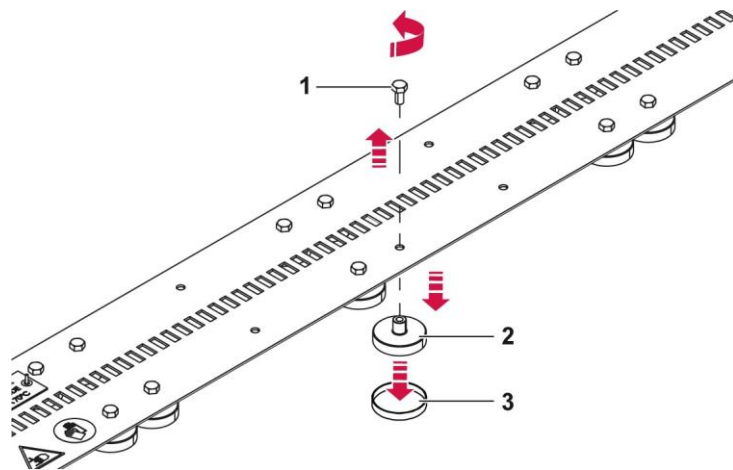

- 1) Clean the rail to make sure that it is free of metal dust and parts.



WARNING!

Safety goggles mandatory (danger of projectiles).



WARNING!

Protective gloves mandatory (risk of crushing when handling equipment).



WARNING!

For an HT rail, wait until it has cooled down completely before handling it (risk of burns).

- 2) Remove the bolts (1) to remove the magnet (2).
- 3) Replace magnet (2).



NOTE!

For an HT rail, replace the magnet with an HT version (with or without cap – depending on position on the rail).

- 4) Install the bolts (1) again to replace the magnet (2).
- 5) If several magnets need to be replaced, repeat the procedure.

7.3 Changing the rollers

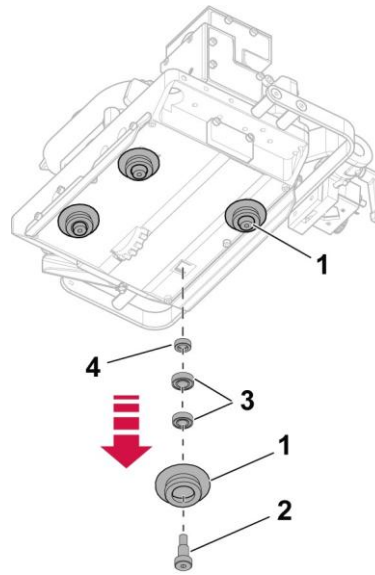

- 1) Loosen the screw (2) to remove the pulley (1).

**WARNING!**

The guide roller is held in place by two bearings (3) and a spacer (4). Take care not to lose them when disassembling and reinstall them in the correct order when reassembling.

- 2) Repeat the procedure to remove the four guide rollers (1).
- 3) Install in the reverse order.

8 TROUBLESHOOTING

Carry out these checks and inspections before sending the unit to an authorized service technician.

Type of fault	Possible causes of errors	Remedial measure
Remote control does not turn on	The remote control battery is empty	Charge or replace the remote control battery
Axis missing on screen	The axis is incorrectly connected or the cable is defective. Wrong axle configuration.	Reconnect the axis to a free accessory port or replace the cable.
Remote control cannot be paired.	The remote control is not assigned to the right cart.	Check that the serial number displayed in the search bar of the remote control matches the serial number on the cradle nameplate.
The arc detector does not work.	The tool holder jaw is mounted to the rear.	Mount the tool holder properly.

Remote control fault code	Solution
Trolley limit switch warning	If there is a limit switch on the trolley: The fault is displayed when the limit switch is active.
Low battery warning indicator	Charge or replace the trolley battery.
Rotor stop alarm (Y or Z)	The error is displayed when the axis (Y or Z) is at the end stop or something is blocking its movement.
T-Axis Stop Warning	The error is displayed when the T-axis is at the end stop or something is blocking its movement.
System error (X)	Contact customer service and report error number "X".
Remote control connection error	If the cradle is configured with the timeout option (cycle interrupted if the cradle/remote connection is lost): The error is displayed if the remote control is lost.
Version mismatch	The error is displayed if the software versions are not compatible: <ul style="list-style-type: none"> • Carriage/remote control (alternating with remote control connection error). • Axis/remote control (alternating with error "X" axis).
Axis error (Y, Z or T) missing	The error is displayed if the axis (Y, Z or T) is disconnected during a cycle.
Motor error (1 or 2) carriage	The error is displayed if the feed motor overspeeds or the cradle does not reach its feed speed

9 ORDERING SPARE PARTS



CAUTION!

Repairs and electrical work should be carried out by an authorized ESAB service technician. Only use genuine ESAB spare parts and wear parts.

The Mech MIG rail carriages are designed and tested according to the international and European standards **ISO 12100,60204-1, EN IEC 60974-1, EN IEC 60974-5, EN IEC 60974-10**. After completion of maintenance or repair work, it is the responsibility of the person(s) performing the work to ensure that the product continues to comply with the requirements of the above mentioned standard.

Spare parts and wear parts can be ordered through your nearest ESAB dealer, see [ESAB.com](https://www.esab.com). When ordering, please specify product type, serial number, designation and spare part number according to the spare parts list. This facilitates shipping and ensures correct delivery.

APPENDIX



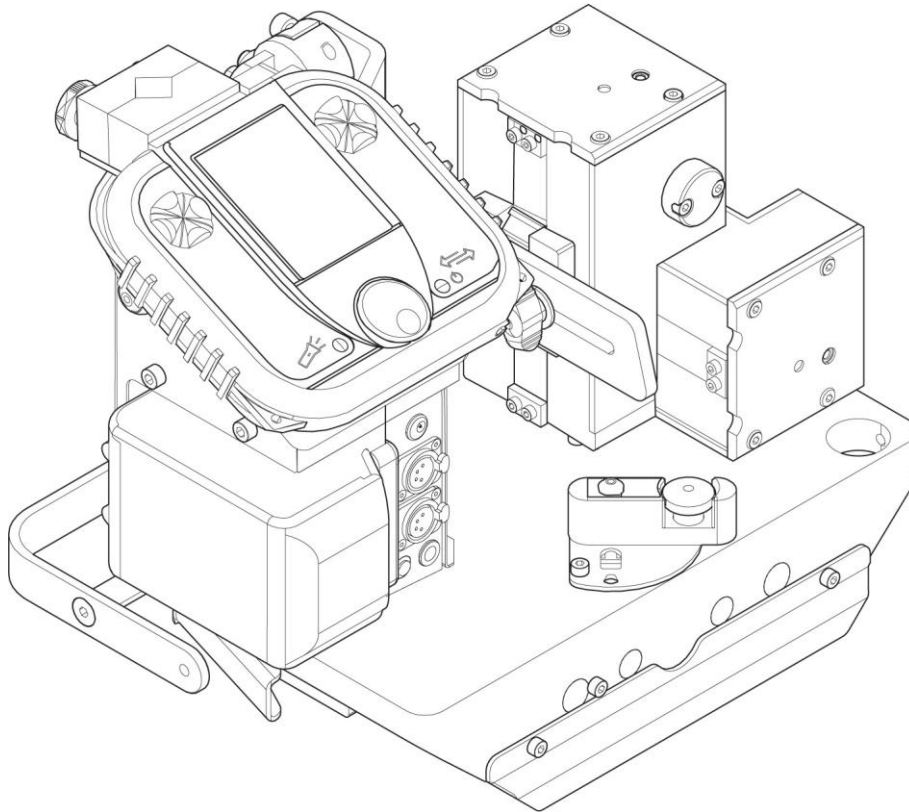



REFERENCES



Ordering Codes	Explanatory Text
A000 101 099	TRACFINDER RAIL Standard Package
A000 101 100	TRACFINDER RAIL Advanced Package
A000 101 218	TRACFINDER RAIL Advanced+ package

The technical documentation is available on the Internet at: www.esab.com



Accessory Items

0464 752 434	Connection bracket – motor shaft	
0464 752 538	Communication box (Modbus)	
0464 752 540	Large manual chute L 100 mm	
0464 752 552	High temperature burner holder (max. 250 °C)	
0464 752 555	Long arm L 400 mm	
0464 752 556	Extra long arm L 700 mm	
0464 752 560	Angle adjustment arm	
0464 752 588	Power supply connection cable L = 600 mm	

APPENDIX

0464 752 592	Standard magnetic flexible rail L 1500 mm	
0464 752 593	Magnetic bending rail half-long L 750 mm	
0464 752 594	High temperature (180 °C max.) magnetic flexible rail L 1500 mm	
0464 752 595	Magnetic flexible rail half length for high temperatures (max. 180°C), L 750 mm	
0464 752 604	Reinforced magnetic rail L 1500 mm	
0464 752 605	Rail end stop sensors	
0464 752 606	Angle torch holder complete for MIG-MAG	
0464 752 608	Joining plate – motorized Y-axis – manual Z-axis	
0464 752 610	Power supply connection cable L = 750 mm	

APPENDIX

0464 752 613	Additional magnetic end of the flexible web	
0464 752 615	Additional high temperature magnetic plate (max. 180 °C)	



A WORLD OF PRODUCTS AND SOLUTIONS.



Contact information can be found at esab.com

ESAB AB, Lindholmsallén 9, Box 8004, 402 77 Gothenburg, Sweden, telephone +46 (0) 31 50 90 00

manuals.esab.com

